

Changing Carpet
Care Forever

The Next Generation of Carpet Care

All
New



ECO 500 AW SERIES of
Recycling Extractors

Moisture-Controlled Cleaning

ECO 500 AW • ECO 500 AW PLUS



Faster, Cleaner, Greener.

Next Generation: ECO 500 AW Series Recycling Extractors

Portable, Professional-Grade



One Machine Does it All

CFR's all new portable ECO 500 AW Series upright extractors equip carpet cleaning professionals with all of the tools required to achieve contractor-grade, deep-cleaning results. These ten and fifteen gallon workhorses are designed to meet a multitude of cleaning demands, and are equipped with all-new advanced technology, high-efficiency air-watt motors for increased cleaning performance. The ECO 500 AW Series upright extractor provides superior flexibility for smaller spaces, portability, and tackles virtually any cleaning task including restorative carpet care, stairs, upholstery, fabric office partitions, and even hard surfaces with grouted tile. With convenient, cost-effective, disposable filters, the ECO 500 AW Series is perfect for cleaning crews on the go.

LATEST, MOST ADVANCED MOTOR TECHNOLOGY ON THE MARKET TODAY

Working with the leading global manufacturer of innovative motor technology, CFR is proud to introduce the most advanced, highest-performing, vacuum motor available in the industry today. Incorporating this new vacuum motor, which was specifically designed for foam and moisture-laden applications, CFR's ECO 500 AW Series delivers industry leading performance, with less amperage, noise, and energy consumption.

Measured in "Air Watts" instead of older terms or industry jargon to define vacuum performance, CFR's new ECO 500 AW Series leaves the competition behind. Featuring "Eternity" carbon brushes, vacuum motor life on the ECO 500 AW Series is three to five times longer than those found in traditional extractors.

Even more impressive, the state-of-the art motor technology found in CFR's ECO 500 AW Series eliminates bearing failure, which is the number one failure mode found on carpet extractor vacuum motors. By protecting and moving the bearings away from the moisture stream, employing advanced moisture shields, and relocating the cooling fan and commutator to maximize cooling airflow to the hottest areas of the motor, the ECO 500 AW Series delivers industry leading performance and increased productivity for years to come.

CFR.....machines that last longer, outperform and lead the industry in productivity, through patented Faster, Cleaner, Greener Technology!

Faster, Cleaner, Greener.

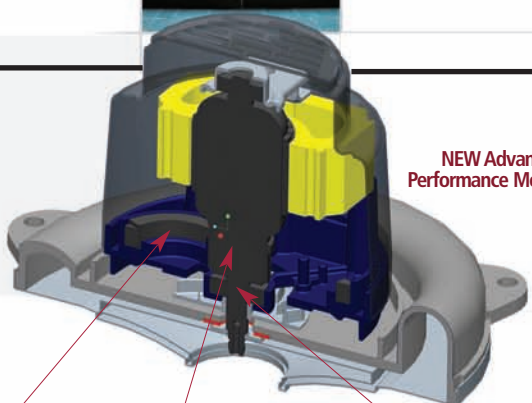

NEW Advanced Performance Motor

New "Eternity" Carbon Brushes Airflow maximized to cool the motor more efficiently
Cooling Fan / Communicator relocated for improved performance

State-of-the-Art Bearing Protection For Longer Lifecycle

1. Bearings moved to clean dry area of motor
2. Additional Protection from Relocated Cooling Fan (between fan system and bearing)
3. Bearing isolated with a seal
4. Additional bypass prohibits water near dry area - secondary bearing protection

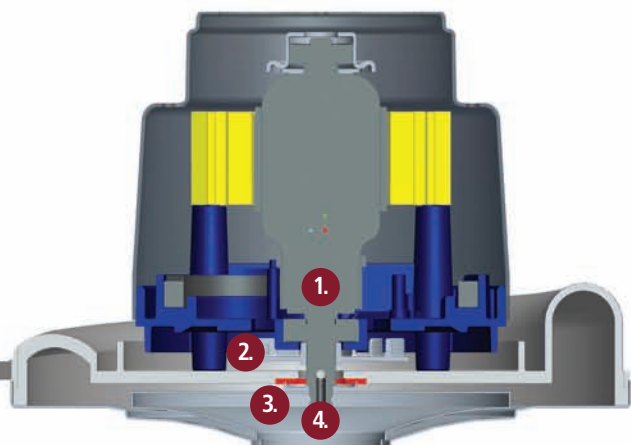



Innovative Cleaning Technology

Unique Rapid Recovery Process Controls Moisture, Sprays, Cleans and Recovers All in One Step

The ECO 500 AW Series innovative solution and recovery process atomizes the cleaning solution injected into carpets to control moisture, neutralizing micro organisms and organic substances that can cause odor.

1. Faster:

CFR's new Recycling Filtration process efficiently and effectively recycles cleaning solution and drastically reduces time spent emptying and refilling. **Overall productivity increases up to seven times that of a traditional carpet extractor.**

2. Cleaner:

High pressure solution blasts soil from carpet fibers for a more powerful clean. The patented air-induction tools atomize the high pressure solution to scrub individual fibers and simultaneously recover the solution to prevent overwetting and reduce re-soiling rates.

3. Greener:

Recycling Filtration extends water usage by over seven times that of traditional carpet cleaners. Chemical usage is also greatly reduced which **saves money and reduces the impact on the environment through less chemical and packaging waste.**

Broad-range Applications:

- Schools and Universities
- Hospitals and Healthcare Facilities
- Nursing Homes
- Hotels and Resorts
- Restaurants
- Government Facilities
- Commercial Buildings
- Casinos

Unique Rapid Recovery Process

Controls Moisture, Sprays, Cleans and Recovers All in One Step

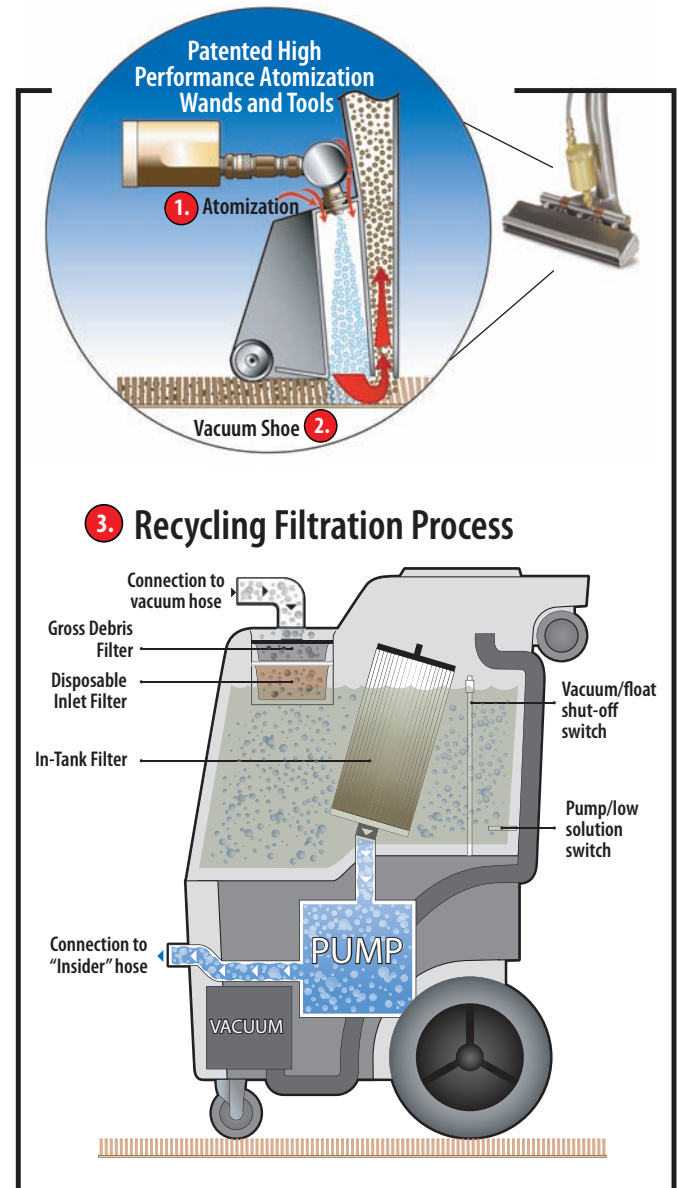

Recycling Filtration

State-of-the-art filtering technology

Recovered solution and debris first pass through a Gross Debris Filter, then through a Disposable Inlet Filter and into the main solution tank. Solution is then drawn through the In-Tank Filter with over 990 square inches of filtering media. Cleaning solution is then pumped at 500 psi through a wand-mounted final filter, dramatically increasing productivity in an eco-conscious manner.



Intake solution while cleaning Same solution after filtering



1. Wheeled handle for easy loading
2. Hinged tank design for easy access to internal components
3. Front mounted pressure gauge / adjustment knob to monitor cleaning performance
4. Front mounted drain hose for fast solution disposal
5. Easy access to all filters for routine maintenance and cleaning
6. Rear mounted control panel and power outlets feature sealed membrane switches

Cleaning Comparisons - Cleaning 5,000 Square Feet

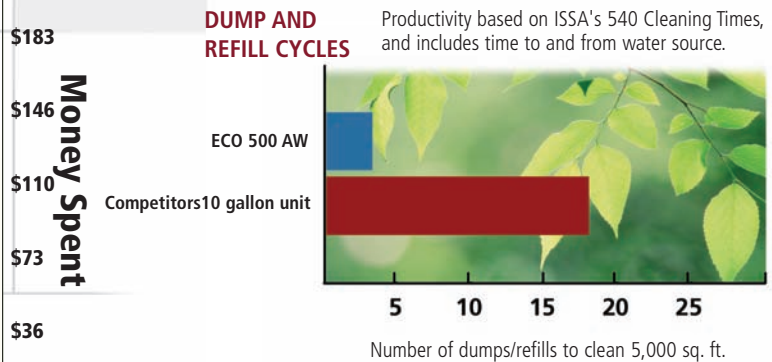
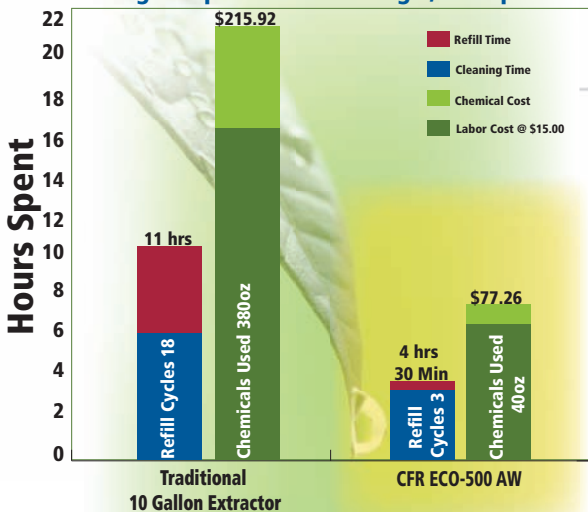

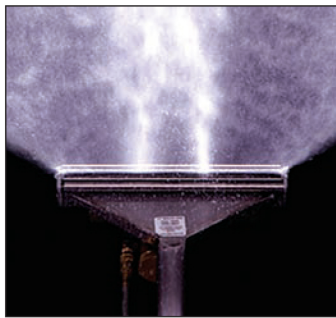

Patented air induction tools clean better and recover solution faster.



Moisture-controlled cleaning systems meet the requirements of the U.S. Green Building Council LEED E-B.

Available without heat, and with heat for those applications where particularly stubborn stains are common, for that extra boost of cleaning power.

Base Unit (Machine Only)	
Description	Model
ECO 500 AW	10468B
ECO 500 AWH	10468C
ECO 500 AW Plus	10470B
ECO 500 AWH Plus	10470C

CFR CHEMICAL SYSTEMS

Specially formulated for CFR's machines and containing no volatile organic compounds (VOCs) or harmful ingredients, our recycling technology minimizes your fill and re-fill efforts. One tank of chemical will perform up to seven times the amount of usage compared to other cleaning chemicals. This results in drastically reduced cost of the chemical down to 3 cents per gallon in use.

CFR is proud to offer our specially formulated CFR chemicals in a U.S. EPA approved formula. By using these chemicals and a CFR carpet extractor, you will be operating the only truly "green" carpet cleaning system in the industry.

SPECIALTY TOOLS

The ECO 500 AW Series uses CFR's patented, high performance hand and floor tools to clean congested carpeted areas, upholstery, fabric or covered walls, and fabric office partitions. The unit can even be used on hard surfaces such as grouted tile, walls and floors.



U.S. EPA DfE approved chemicals available



Recognized for Safer Chemistry
www.epa.gov/dfe



Atomization hand tool can even be used for cleaning office partitions!

EPA/DfE recognition does not constitute endorsement of this product. The Design for the Environment logo signifies that the formula for this product, as CFR Corporation has represented it to the EPA, contains ingredients with more positive health and environmental characteristics than conventional cleaners. EPA/DfE relies solely on CFR Corporation, its integrity and good faith, for information on the composition, ingredients, and attributes of this product. EPA/DfE has not independently identified, i.e., via chemical analysis, the ingredients in the product formula, nor evaluated any of CFR Corporation's non-ingredient claims. EPA/DfE provides its evaluation only as to the environmental and human health characteristics of the product, based on currently available information and scientific understanding.

ECO 500 AW COMPLETE CLEANING SYSTEM

Product	ECO 500 AW	ECO 500 AWH	ECO 500 AW Plus	ECO 500 AWH Plus
Model	10468B-K	10468C-K	10470B-K	10470C-K
Base Unit (Machine only)	10468B	10468C	10470B	10470C
Electric Heater	NA	110V 1650W	NA	110V 1650W
Tank Size	10 gal.	10 gal.	15 gal.	15 gal.
Machine Dimensions (LxWxH)	29" x 20" x 35"	29" x 20" x 35"	29" x 20" x 40"	29" x 20" x 40"
Body Weight	86 lbs.	96 lbs.	88 lbs.	98 lbs.
Vacuum Motor	Single, 6.6 dia AW	Single, 6.6 dia AW	Single, 6.6 dia	Single, 6.6 dia
Peak Airwatts	673	673	673	673
Maximum CFM	141	141	141	141
Solution Pump (Adjustable p.s.i.)	500 psi(34.5 BAR)	500 psi(34.5 BAR)	500 psi(34.5 BAR)	500 psi(34.5 BAR)
Pump Motored	1/4 HP DC	1/4 HP DC	1/4 HP DC	1/4 HP DC
Power (V/Amps)	120V, 15A	120V, 15A/ each circuit	120V, 15A	120V, 15A/ each circuit
Power Cord	25' detachable	Dual 25' detachable	Dual 25' detachable	Dual 25' detachable
Front Wheel Dimensions	Two 4" dia. swivel casters	Two 4" dia. swivel casters	Two 4" dia. swivel casters	Two 4" dia. swivel casters
Rear Wheel Dimensions	Two 10" dia. Wheels	Two 10" dia. Wheels	Two 10" dia. Wheels	Two 10" dia. Wheels
11" Rapid Recovery Wand (Type R)	Included in 10468B-K Kit	Included in 10468C-K Kit	Included in 10470B-K Kit	Included in 10470C-K Kit
3" Combination Tool	Included in 10468B-K Kit	Included in 10468C-K Kit	Included in 10470B-K Kit	Included in 10470C-K Kit
33' Flexible Hose - 1,500 P.S.I (1.5")	Included in 10468B-K Kit	Included in 10468C-K Kit	Included in 10470B-K Kit	Included in 10470C-K Kit
Parts / Labor Warranty	1 year*	1 year*	1 year*	1 year*
Tank Warranty	5 year*	5 year*	5 year*	5 year*

* See full warranty for details Note: Use of defoamer is recommended

Make A Difference with CFR

Cleaning for Health and Sustainability

Studies show:

- On average, Americans spend about 90 percent of their time indoors.
- Approximately 84 million Americans (including 73.7 million students) spend their days in schools, colleges and universities.
- Volatile Organic Compounds (VOCs) and other pollutants are found in concentrations two to five times greater indoors than outdoors.
- 30% of U.S. workers suffer from health problems caused by Sick Building Syndrome, yet many companies underestimate the benefits of green cleaning, which can reduce VOCs and improve Indoor Air Quality (IAQ).
- More than 20 million people, including over 6 million children, have asthma, accounting for over 10 million outpatient clinic visits and nearly 2 million emergency room visits annually.
- Indoor contaminants such as dust, mold, mites, insect and pest droppings, dander, and others can significantly increase the occurrence of asthma and allergy attacks.
- Less than 1% of the Earth's water is available for human use, and due to this lack of clean water is the world's biggest cause of infection.
- 50% of schools in the world do not have access to clean, fresh water and as a result, each year 443 million school days are lost.



At CFR, we are passionate about creating clean, healthy and safe indoor and outdoor environments, and water preservation, moisture-control and recycling are critical components.



Faster, Cleaner, Greener.

3101 Wichita Court
Fort Worth, TX 76140-1755

800.533.2557 • Fax 817.551.0719
www.cfrcorp.com

TACONY

A Tacony Company



Contains 30% post consumer waste.
Form #: CFR131-2 - 8/13. Printed in the USA.