

WINCO INC[®]

INSTALLATION INSTRUCTIONS 2 WHEEL DOLLY KIT

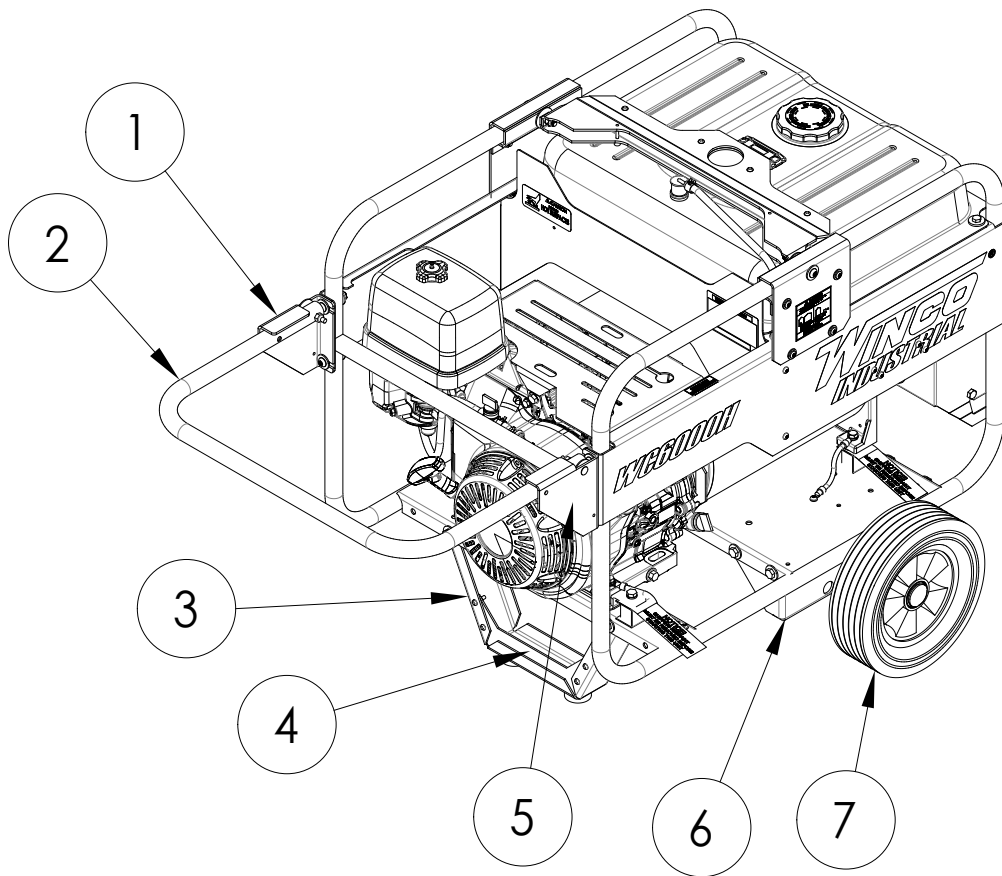

COMPONENT LIST

REF. #	PART #	DESCRIPTION	QTY.
1	300066-16	Left Handle Support	1
2	61857-009	Handle	1
3	16205-005	Foot	1
4	16205-006	Foot Support	1
5	300066-17	Right Handle Support	1
6	15775-020	Axle Bracket	2
7	43657-008	Wheel & Tire	2
8	64326-025	Axle	1
Not Illustrated	15687-027	Heat Shield	1
Not Illustrated	16199-126	Parts Bag	1

STEP 1

- Open hardware bag and account for all fasteners and components.

FASTENERS & MISC. COMPONENTS (not shown in actual size)

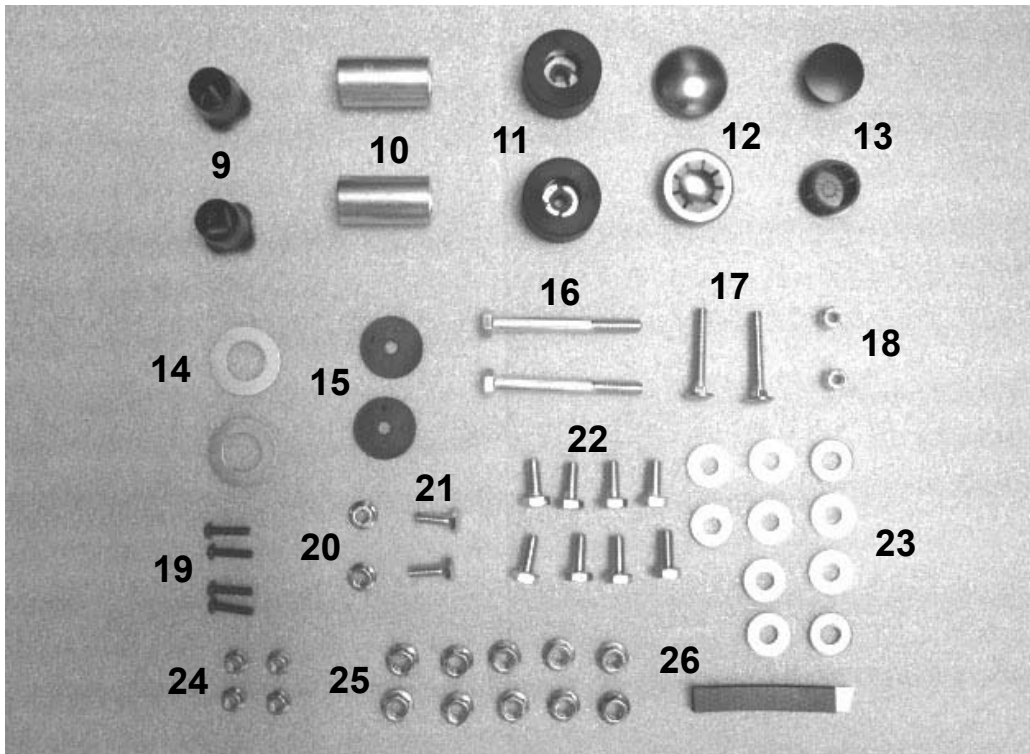

FASTENER & COMPONENT LIST

REF #	PART #	DESCRIPTION	QTY
9	16343-000	Axle Shaft Protector	2
10	64688-007	Spacer	2
11	20191-000	Shock Mount	2
12	64327-000	Hubcap	2
13	93402-001	Hole Plug	2
14	1178-000	Flat Washer	2
15	96286-006	Nylon Flat Washer	2
16	57523-000	5/16"-18 X 3" Bolt	2
17	56842-004	1 3/4" Carriage Bolt	2
18	47517-000	1/4"-20 Nylock Hex Nut	2
19	420-001	#10-24 X 3/4" Screw	4
20	16248-000	1/4"-20 Flange Nut	2
21	466-000	1/4-20 X 3/4" Bolt	2
22	467-000	5/16"-18 X 3/4" Bolt	8
23	526-000	Flat Washer	10
24	99671-000	#10-24 Hex Nut	4
25	16249-000	5/16"-18 Flange Nut	10
26	62912-000	1/2" Foam Strip	1

STEP 2

- Remove the generator from the pallet and block generator up 8 to 10 inches to gain access to the bottom of the cradle assembly. A lifting jack or hoist may also be used if available.

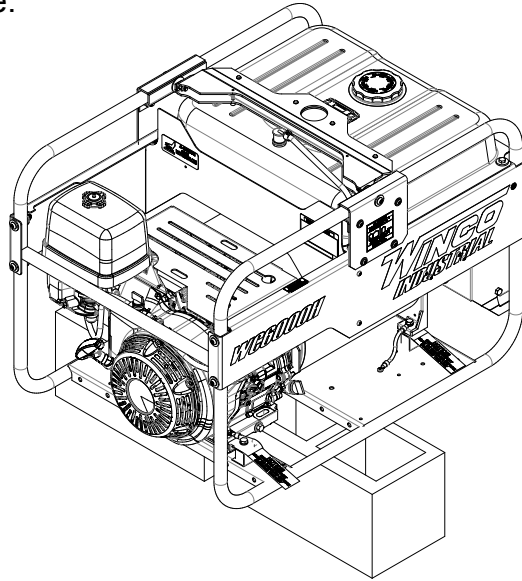

STEP 3

- Attach foot support (ref. 4) to the inside of foot (ref. 3) using hardware (ref. 19 & 24). Leave these loose until the foot support is attached to the cradle.
- Bolt shock mounts (ref. 11) to the bottom of the foot bracket (ref. 3) using hardware (ref. 20 & 21). Place foot bracket (ref. 3) into the front cross channel of the cradle and bolt on with hardware (ref. 16, 23, 25). Tighten all hardware.

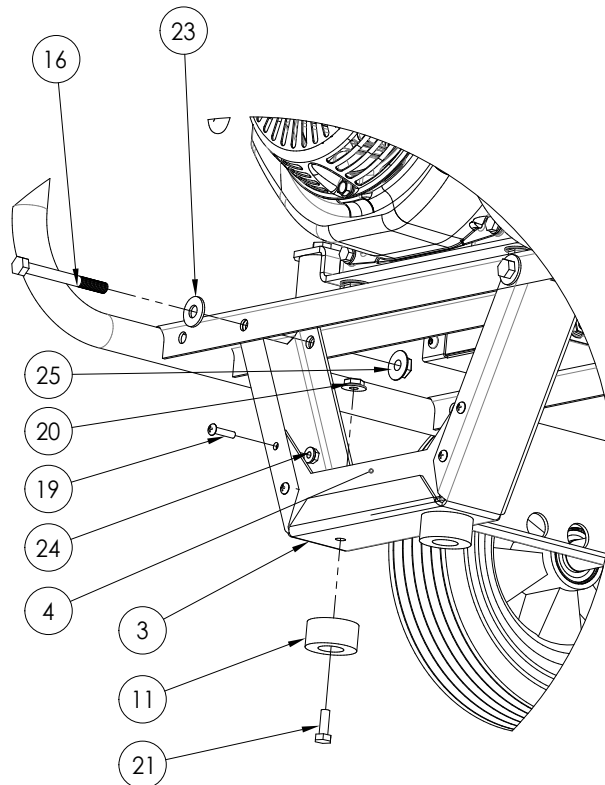

STEP 4

- Place both axle brackets (ref. 6) into the rear cross channel of the cradle and bolt on with hardware (ref. 22, 23, 25)
- Remove and discard axle protectors (ref. 9). Place spacer (ref. 10), wheel (ref. 7), washer (ref. 14) on the axle. Then tab the hubcap (ref. 12) on the axle. Then slide assembly through the two axle brackets. Place other spacer, wheel and washer on axle and lower to the ground. Place the other hubcap on the axle.
- Remove the bottom two torx screws from the heat shield (A). Place the additional heat shield in place and replace the two torx screws.

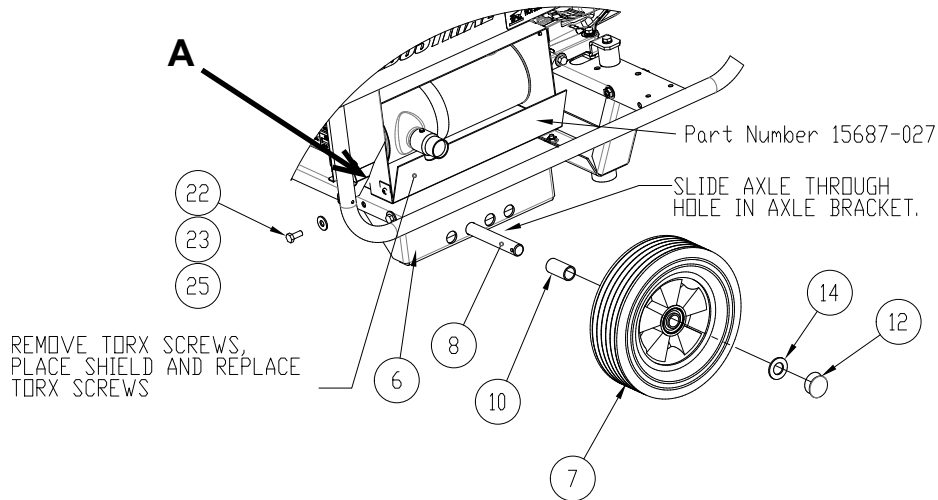

STEP 5

- Install hole plugs (ref. 13) into ends of handle (ref. 2). Cut the foam strip (ref. 26) in half using a scissors. Apply to the underside of the handle supports (ref. 1 & 5).
- Bolt left and right handle supports (ref. 1 & 5) to the cradle using hardware on cradle. Attach handle (ref. 2) using hardware (ref. 17, 15, 18). Tighten the nylock hex nuts. Do not over-tighten so that the handle will move freely.

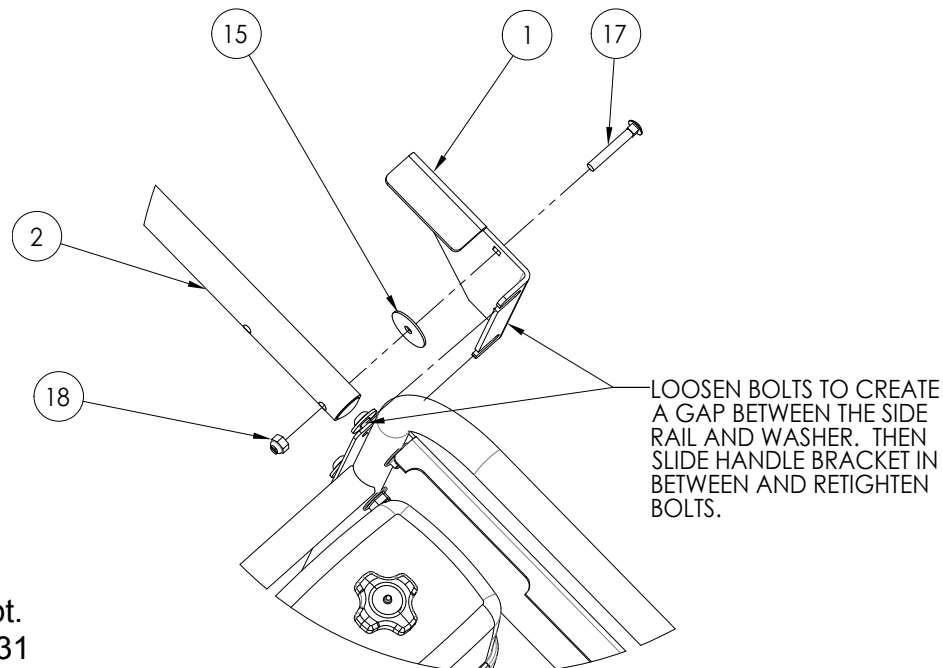

Winco Inc.
Service Dept.
507-357-6831