

Safety, Operations & Maintenance Manual



Cleanfix[®] Sparrow

This unit is intended for commercial use

This manual is furnished with each new **Sparrow**. It provides necessary operation and maintenance instructions.

READ AND FOLLOW ALL INSTRUCTIONS, WARNINGS AND CAUTIONS BEFORE AND WHEN USING THIS EXTRACTOR.

All information and specifications printed in this manual are current at the time of printing. However, because of Cleanfix's policy of continual product improvement, we reserve the right to make changes at any time without notice.

WHEN THE MACHINE IS DELIVERED

This extractor will afford you many years of trouble-free operating satisfaction, provided it is given proper care. All parts are passed rigid quality control standards prior to their being assembled to the finished product. Prior to packaging, your extractor was again inspected for assurance of flawless assembly.

This carpet extractor is protectively packed to prevent damage in shipment. When the machine is delivered carefully check the carton for signs of damage. Unpack the machine from the carton and inspect it for any possible damage.

Only a visual examination will reveal damage that may have occurred in transit. If damage is discovered, immediately notify the transportation company that delivered your extractor and request an inspection. As a shipper we are unable to report any claim for damage. You must origin any claim within 5 days of delivery. Be sure to keep the carton, packing inserts, packing list and carrier's receipt until the inspector has verified your claim. **CLEANFIX'S LIABILITY CEASES WHEN THE SHIPMENT IS PICKED UP BY THE CARRIER.** Cleanfix will furnish any information needed to expedite the claim process.

GENERAL PRECAUTIONS

FAILURE TO FOLLOW PRECAUTIONS AND WARNINGS MAY CAUSE SERIOUS INJURY TO THE OPERATOR AND CAUSE DAMAGE TO MACHINE, WHICH CAN VOID WARRANTY. TO REDUCE RISK OF FIRE, ELECTRIC SHOCK OR INJURY: READ ALL INSTRUCTIONS BEFORE AND WHEN USING THIS EXTRACTOR.

WARNING

To Avoid Electric Shock, Do Not Expose to Rain. Store Indoors.

- For 120 volt grounded outlet models. The unit must be plugged into a properly grounded outlet. **Do not** operate the machine with a broken/missing grounding pin. Have a qualified service person replace the plug immediately.
- **Do not** leave the extractor when plugged in. Unplug from outlet when not in use and before servicing.
- Turn **OFF** all the controls before unplugging the extractor.
- This is **NOT** a toy. Close attention is necessary when used around or near children.
- Use only as described in this safety/operations manual. Use only manufacturer's recommended attachments and accessories.
- **Do not** use this extractor with damaged cord or plug. If the extractor is not working as it should, because it has been dropped, damaged, left outdoors or dropped into water, contact authorized service center or factory.
- **Do not** pull or carry extractor by the cord, use cord as a handle, close a door on cord or pull cord around sharp edges and corners. **Do not** run extractor over cord. **Keep** cord **away** from heated surfaces.
- Replace damaged or worn parts immediately with genuine original equipment parts to maintain safety and to protect your limited warranty.
- **Do not** run pump dry. When solution tank is empty, turn off the pump.
- **Do not** use Solvents with this unit.
- Use only liquid detergents, powders do not fully dissolve and damage the motor.
- **Do not** unplug the extractor by pulling on the cord. To unplug, grasp the plug, not the cord.
- **Do not** handle the plug of the electric extractor with wet hands.
- Store extractor indoors in a dry area. **Do not** expose to freezing temperatures.
- **Do not** use this extractor for dry vacuuming. This extractor is not fitted with a fine dust filter.
- **Do not** use the extractor to pick up flammable or combustible liquids such as gasoline or use in areas where they may be present.
- **Do not** use this extractor to clean surfaces that have dust or substances that are flammable, poisonous, caustic, or irritants and represents a health hazard.
- **Do not** use where anesthetics or oxygen is used.
- **Do not** use an extension cord unless absolutely necessary. If an extension cord is used, the wire size must be 14 ga. or larger and should not exceed 50 feet in length. The extension cord must be three-wire type to insure grounding protection.
- **Do not** put any objects into openings. **Do not** use with any opening blocked; keep free of anything that may reduce air flow.
- Keep hair, loose clothing, fingers, and all parts of body away from openings and moving parts.
- **Do not** use water over 120° F.
- **Always use defoamer.** Foam will suspend particles and moisture will damage the motor.

CARE OF THE EXTRACTOR

This extractor is designed to be safe when used to perform cleaning functions as specified. Should damage occur to electrical parts, the unit should **NOT** be used until the damage is repaired by the manufacturer or an authorized service center. This will avoid further damage to the extractor or injury to the user.

These instructions are for your protection and information.

PLEASE READ CAREFULLY! Failure to follow instructions or precautions could result in injury or damage to the user and/or the extractor.

SAVE THESE INSTRUCTIONS!

GROUNDING INSTRUCTIONS - 120 VOLT

Electrical equipment must be grounded. If it should malfunction or breakdown, grounding provides a path of least resistance for electrical current to reduce the risk of electric shock.

The extractor is equipped with a cord having equipment grounding conductor and grounding plug.

The plug must be inserted into an appropriate outlet that is properly installed and grounded in accordance with all local codes and ordinances.

If repair or replacement of the cord or plug is necessary, **DO NOT** connect the grounded wire to either flat blade terminal. The wire with insulation having an outer surface that is green with or without yellow stripes is the grounding wire.

WARNING

Improper connection of the equipment-grounding conductor can result in a risk of electric shock. Check with a qualified electrician or service person if you are in doubt as to whether the outlet is properly grounded.

Do not modify the plug provided with the equipment. If it will not fit the outlet, have a proper outlet installed by a qualified electrician.

Note: In Canada, the use of a temporary adaptor is not permitted by the Canadian Electrical Code.

GROUNDING METHODS

This electric equipment is for use on a nominal 120-volt circuit, and has a grounded plug that looks like the plug illustrated in (Fig. A). A temporary adaptor that looks like the adaptor illustrated in (Fig. B & C) may be used to connect this plug to a 2-pole receptacle as shown in (Fig. B) if a properly grounded outlet is not available.

The temporary adaptor should be used only until a properly grounded outlet (Fig. A) can be installed by a qualified electrician. The green color rigid ear, lug or the like extending from the adaptor must be connected to a permanent ground such as a properly grounded outlet box cover. Whenever the adaptor is used, it must be held in place by a metal screw (Fig. C).

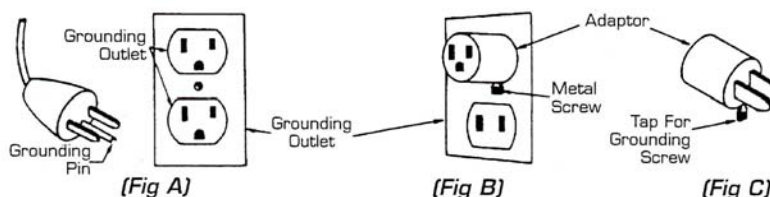

DANGER:

Improper use of the grounding plug can result in a risk of electrical shock.

BEFORE USING THE EXTRACTOR

1. Remove furniture from the area to be cleaned. Large pieces can be removed to opposite end of the room from where you start cleaning.
2. Vacuum carpet or dirty spots thoroughly to remove all loose debris.
3. Make sure the switch is in the **OFF** position.
4. All extractors are shipped with anti-freeze (Summer or Winter) in the pump and solution lines. Fill the tank with 1 quart of warm water and flush out the system prior to use. Attach the hoses and with hand-toll spray one quart of warm water through the pump.
5. Lift up the recovery tank and fill the base unit with clean warm water using a clean bucket or a hose attached to a water source (3 gal. maximum capacity). Fill to approximately 4" from the top.
6. Add the chemical required made for carpet cleaning or upholstery. Check the label for the correct dilution portions.
7. If you are using heated water, the temperature should not exceed 120° F. This improves the cleaning effectiveness when removing oil or grease from the carpet.
8. Before plugging power cord into grounded outlet all switches must be in the **OFF** position.

NOTE: A non-foaming chemical must be used. Carpet that has been previously cleaned may have a heavy build-up of old shampoo residue which may cause excessive foaming in the recovery tank and could damage the vacuum motor. Always use defoaming agent.

WARNING

DO NOT operate extractor without a cord ground pin. This is necessary to avoid electric shock.

FUNCTIONAL PARTS AND ACCESSORIES

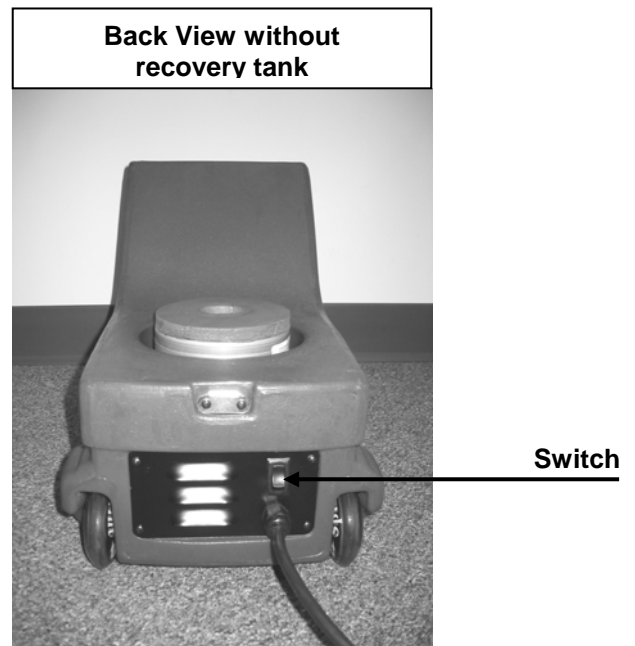
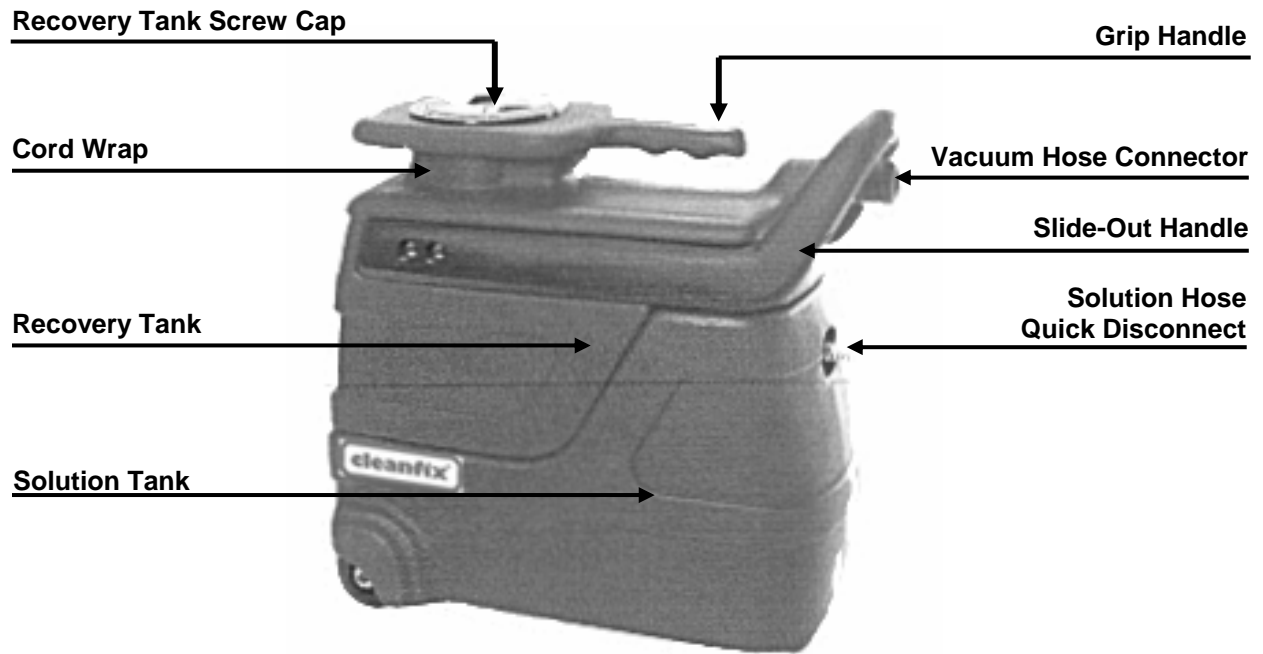

TO OPERATE AS A EXTRACTOR

1. Prepare the carpet surface by vacuuming before using the extractor.
2. Make sure all the switches are OFF.
3. Select the proper floor brushes or pad drivers and floor pads for the cleaning operations.
4. Fill a clean bucket with clean water, and pour it into the solution tank opening, maximum capacity 3 gallons.
5. Add the chemical required. Check the label for dilution rates. Add the defoamer.
6. Attach the 1-1/2" vacuum hose to the vacuum hose connector.
7. Attach the brass quick disconnect of the solution hose to the solution hose quick disconnect on the machine.
8. Plug in the power cord, turn on the switch.
9. Start cleaning by squeezing the solution lever at the tool and placing the tool over the spot/area to be cleaned.
10. Periodically check the solution level in the tank. NEVER allow pump to run dry, otherwise both the pump and the carpet may be damaged.
11. Before refilling the solution tank, flush the recovery tank with clean water.

IMPORTANT

Vacuum Shut Off!

The sparrow is designed with a vacuum restrictor to reduce the vacuum when the recovery tank is full. When the vacuum is restricted the liquid will not travel up the clear-view nozzle. The motor speeds up (the sound will change), this is your notice to dispose of your recovered solution. The restrictor is a foam float that slides up and down the standpipe in the recovery tank.

ROUTINE MAINTENANCE

If you maintain this extractor carefully it will stay in working order for a long period of time. Check the unit regularly for any wear and tear.

1. DO NOT clean the extractor with pressure washer.
2. When servicing or making repairs use only genuine original equipment parts.
3. Repairs and service should only be made by an authorized service center or the factory.
4. Monthly Maintenance: Check all the gaskets, tighten loose nuts and bolts.

TO MAINTAIN THE EXTRACTOR – AFTER EACH USE

Remove the vacuum hose from the upper body, un-clip, rotate latch on the back of the unit and remove upper section of the spotter.

Dump the used solution (pour the used solution back through the outlet that the vacuum hose was connected to) in the toilet or janitors closet sink.

CAUTION

Before working on the extractor disconnect the power cord.

TROUBLESHOOTING

Symptom: Extractor does not run! No power to the machine!

Problem: Blown fuse/circuit breaker in the building / room has tripped.

Solution: *Replace fuse with the same rating. Reset circuit breaker. Make sure no other appliances are connected on the same circuit as the machine. The machine requires a dedicated 15 amp circuit.*

Problem: Frayed cord, damaged plug or loose internal wiring.

Solution: *Have an authorized service technician check cord and replace if necessary. Have an authorized service technician open switch panel and check for loose wire connection.*

Symptom: Insufficient vacuuming power!

Problem: Float in the recovery tank is not at the bottom of the unit.

Solution: *Open the screw cap and push the float down..*

Problem: Vacuum hose not connected.

Solution: *Connect hose.*

Problem: Tank cover not properly seated or gasket on dome cover is damaged.

Solution: *Reseat tank cover correctly or replace gasket.*

Problem: Filter in tank cover blocked.

Solution: *Clean filter with water.*

Problem: Drain plug or recovery tank not properly placed.

Solution: *Check drain plug and replace properly.*

Problem: Defective vacuum motor (noisy bearing, carbon brush sparking burn out armature and worn out carbon brush)

Solution: *Have an authorized service technician replace vacuum motor and motor gasket.*

Symptom: Little or no solution pressure.

Problem: Pump is off.

Solution: *Turn pump on.*

Problem: Solution line blocked.

Solution: *Flush out solution tank and lines with clean water. Also check quick disconnects for debris.*

Problem: Solution tank filter / intake clogged.

Solution: *Unclog filter / solution intake.*

Problem: Pump is not working.

Solution: *Have an authorized service technician check and replace pump.*

Problem: Solution tank empty.

Solution: *Refill solution tank.*

Problem: Spray jets at tool clogged.

Solution: *Remove the jet from the end of the hand-tool and press trigger of tool. If the pump functions clean the jet and/or replace..*

WARNING

Service and repairs should only be performed by an authorized service center.

PARTS LIST

Pos.	Description	Qty.	Ref.
1	Vacuum Tank Lid Assembly	1	355.049
2	1.88 Foam Filter	1	355.072
3	1 ½ Mesh Screen	2	355.073
4	1 ½ ABS Sleeve	1	355.074
5	PVC 1 ½ MT x FMSt	1	355.074
6	1 ½ ID Thin Gasket	1	355.063
7	Recovery Tank	1	355.100
8	Tether	1	355.152
9	Adaptor Strap	1	355.054
10	2" Threaded Cap	1	355.330
11	Cap Gasket	2	355.331
12	1 ½ Locknut	1	355.001
13	Vacuum Gasket	1	355.062
14	115 V, Vacuum Motor	1	355.210
15	Rocker Switch	1	355.076
16	25ft., 16/3 Power Cord	1	355.151
17	Water Shield Gasket	1	355.064
18	Strain Relief	1	355.005
19	Switch Plate	1	355.039
20	¼ " Flat Washer	3	355.002
21	¼ " Coupler	1	355.004
22	3/16 " x 1" Washer	4	355.003
23	¼ " FM Quick Disconnect	1	355.017F
24	¼ " x 1/8 " Nipple	1	355.006
25	QD Retaining Plate	1	355.040
26	¼ " x 1/8 " FMT Push in	2	355.007
27	8" Nylon Tubing	1	355.200
28	¼ " x 1 " Bolt	1	355.008
29	Pump Bracket	1	355.041
30	Bottom Plate	1	355.042
31	10-32 x ½ " Screw	10	355.009
32	¼ " -20 x 2" Bolt	2	355.010
33	115V, 55psi Pump	1	355.191
34	1/8 " Hex Nipple	1	355.011
35	¼ " x 5 ½ Vinyl Tube	1	355.201
36	¼ " x 1/8 " PMT Hose Barb	2	355.202
37	Filter Strainer	1	355.012
38	5/16 Axle Cap	2	355.331
39	5/16 " x 9" Axle	1	355.286
40	3" Wheel	2	355.150
41	Vent Cover	1	355.218
42	Solution Tank	1	355.101
43	Solution Tank Lid	1	355.065
44	#8 x ½ " Oval HD Screw	8	355.013

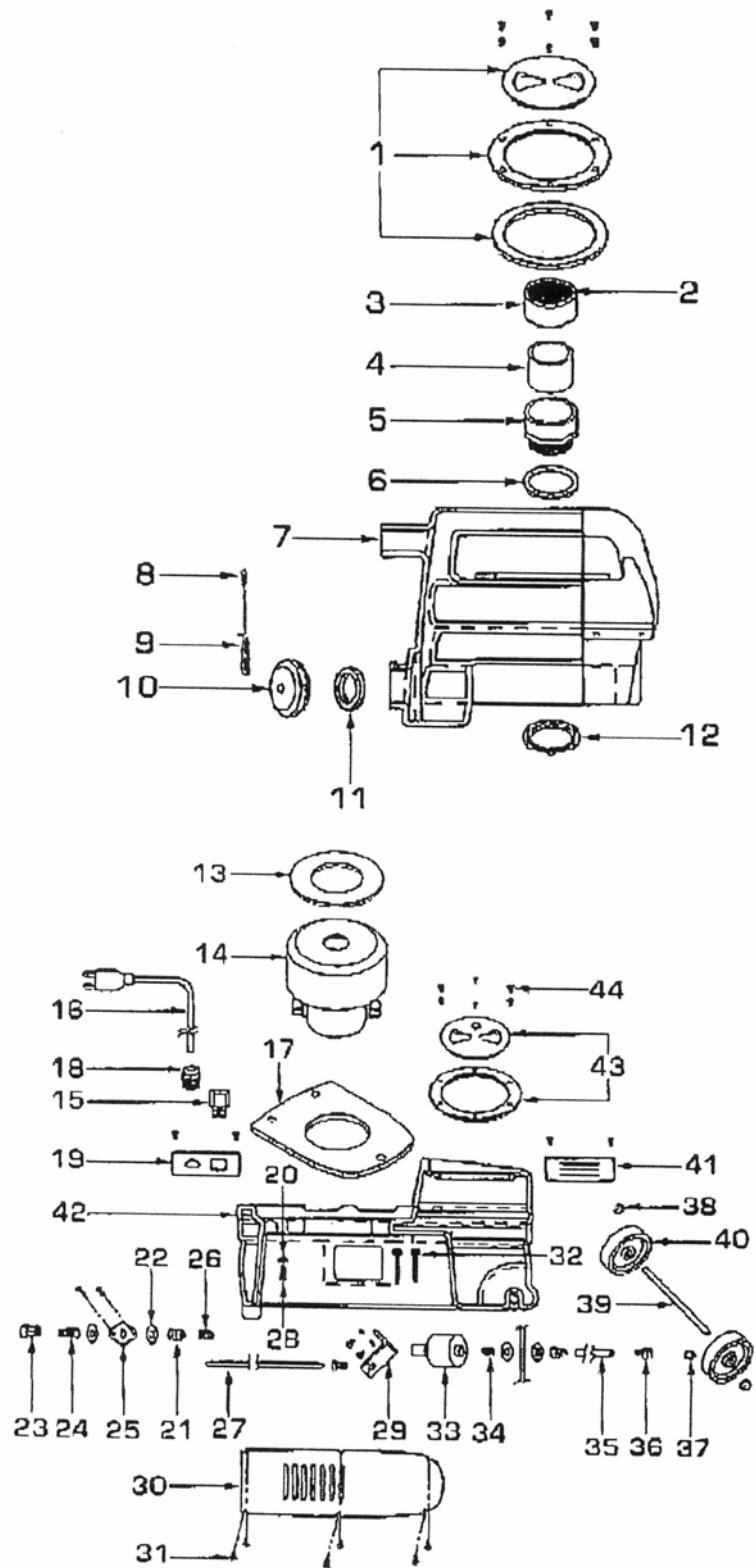

WIRING DIAGRAM

Wiring Diagram

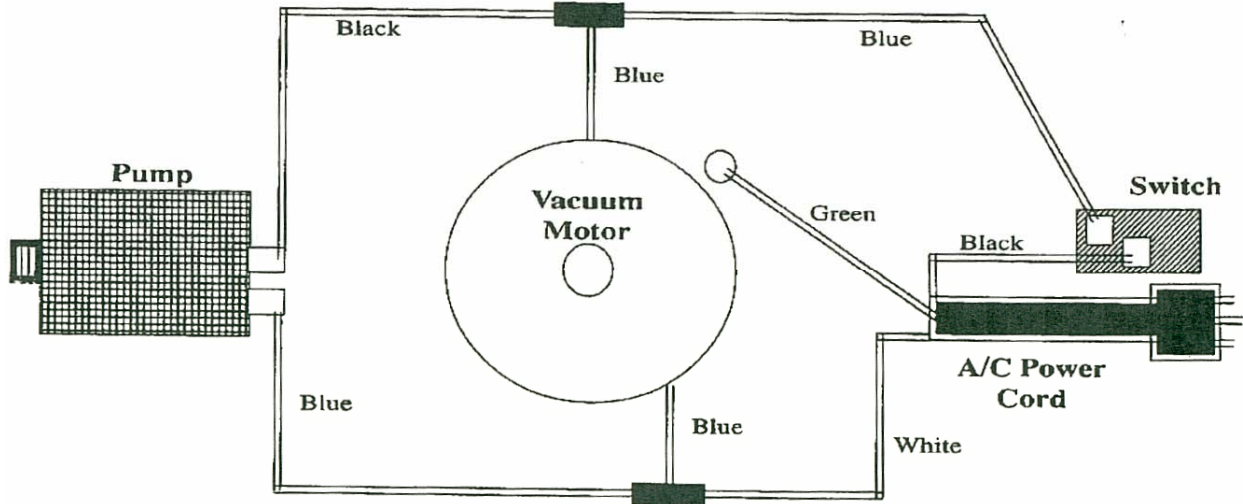

Caution: Color of the electrical wire may vary.
Determine the starting and ending point of each wire to confirm its connection point.

New Machine Warranty



1. Limited Warranty. These terms and conditions of the New Machine Warranty are a material part of the agreement between Buyer and Cleanfix Cleaning Systems Inc., a New Jersey-based corporation (hereinafter "Cleanfix"), and supersede warranty terms and conditions in documentation submitted by Buyer to Cleanfix. Cleanfix warrants new machines of its manufacture against defects in material and workmanship under normal use and service to the original end-user purchaser. No person, agent, representative or distributor is authorized to give any warranties on behalf of Cleanfix, or to assume any other liability for Cleanfix in connection with any Cleanfix machine. Cleanfix reserves the right to make changes to its equipment without notice. The warranty coverage is subject to the conditions below.

2. Registration of Warranty. The warranty commences on the date of purchase by the original end-user from an authorized Cleanfix distributor or agent, subject to proof of purchase. The warranty commences latest, however, after six (6) months of the purchase date by the authorized distributor or agent of Cleanfix. Any new Cleanfix machine must be registered immediately with Cleanfix by the original end-user customer by fully completing and returning the warranty registration form to Cleanfix. If proof of purchase cannot be identified through a completed and returned warranty registration form, the warranty commences from the date of sale to the authorized Cleanfix distributor.

3. Warranty Coverage. Subject to conditions outlined below, Cleanfix warrants rotationally molded PE housings and tanks on all of its machines to be free from defects in material and workmanship, under normal use and service for ten (10) years to the original end-user.

Subject to conditions outlined below, Cleanfix warrants fiberglass housings and tanks on all of its machines to be free from defects in material and workmanship, under normal use and service for three (3) years to the original end-user.

Under this warranty Cleanfix warrants the performance of non-polyethylene and non-fiberglass components to be free from defects and workmanship for up to one (1) year to the original end-user. Parts replaced or repaired under this warranty are warranted for the remainder of the original warranty period. (See table below)

Rotationally molded PE housings and tanks	10 years
Fiberglass housings and tanks	3 years
Vacuum motors, brush motors, pump motors, boards and electronics	1 year
Battery and battery charger*	1 year

* The 1 year period warranty commences with the purchase date by the authorized distributor or agent of Cleanfix.

Service labor charges are covered for up to one (1) year from the date of purchase through an authorized Cleanfix service provider. A total maximum of one (1) hour travel time - equal to one (1) hour labor rate - is covered for large machines, namely Falcon, Raven, Eagle and larger for 90 days. No coverage is extended for diagnosis time.

4. Product Exceptions and Exclusions. ALL vacuum cleaners and air movers are warranted for one (1) year. No warranty is extended for wear items, accessories and attachments including, but not limited to, belts, brushes, pad holders, capacitors, carbon brushes, wheels, casters, glides, clutches, cords, filters, filter bags, gaskets, hoses, rectifiers, switches, float switches, valves, squeegees, bearings, pulleys, relays, actuating cables, wheels, tires, vacuum cleaner attachments.

The purchaser is assured that meticulous care has been exercised in the selection, assembling and testing of these parts and components before shipping. No warranty is extended for machine finish, labels and other cosmetic parts or features.

5. Stated Warranties. Stated warranties are in lieu of all other warranties, expressed or implied. Any statutory implied warranties, including any warranty of merchantability or fitness for a particular purpose, are expressly limited to the duration of the written warranty. Cleanfix will not be liable for any other damages, including but not limited to incidental, indirect or special consequential damages arising out of or in connection with the furnishing, performance, use or inability to use the machine, including damages to persons or property. This remedy shall be the exclusive remedy of the buyer. The warranty is limited to the warranty.

6. Warranty is null and void for the following.

- Damage, defects, malfunction or other failures caused by not using the electric current indicated on the spec plate, including the use of improper extension cords.
- Damage or defect caused by accident, misuse, neglect, abuse, fire etc., including use of incompatible or corrosive chemicals or overloading of capacity.
- Failure caused by lack of proper maintenance and care, including proper machine clean-up after use, proper charging procedures for batteries.
- Failure caused by loss, damage or removal of protective components, including, but not limited to, filters and filter screens, tank covers and lids, skirts and bumpers, float shut-off assemblies.
- Freezing of any water or chemical related components (this will void all warranties on water or chemical related components, internal or external, of the product).
- Deposits and buildup in any water or chemical related systems due to hardness in water (this will void all warranties on affected systems).
- Any design alterations, adjustments and/or repairs performed on the equipment by an organization not authorized or specified by Cleanfix.
- Use of any parts not approved by Cleanfix, including, but not limited to, batteries, battery charger, filter bags, belts, electric components, motors.
- Use of machine for a purpose other than which it was designed and intended, and use of machine in excess of design duration.
- Damage in transit.

7. Warranty Claim Procedure. If a difficulty develops during the specified warranty period, contact the authorized Cleanfix distributor/partner from whom the machine was originally purchased. Do not return any products to Cleanfix unless explicitly authorized by Cleanfix. Cleanfix may elect to require the return of the machine or component(s) to validate the claim. Any defective machine or component to be returned must be shipped freight pre-paid to an authorized Cleanfix distributor/service center.

Cleanfix will provide and charge for replacement parts, including shipping and handling, to the original purchaser through an authorized service center. If the part is returned within 30 days and is found defective, the purchaser will be credited for the cost of the replacement part including shipping and handling.

8. Term. This warranty is valid for all products sold after January 1, 2006. A product sold before that date will be covered by the limited warranty in effect at the date of sale to the original purchaser.