

DRI-EAZ

OWNER'S MANUAL

WARRANTY ∞ OPERATING INSTRUCTIONS ∞ SAFETY
MAINTENANCE ∞ SPECIFICATIONS



**This manual has important safety warnings and operating information.
Please read before using the unit and save for future reference.**

PURCHASE DATE: _____ SERIAL NO.: _____

DEALER: _____

DRI-EAZ PRODUCTS, INC. 1320 Josh Wilson Road, Burlington, WA 98233
1 (800) 932-3030 www.dri-eaz.com

TABLE OF CONTENTS

SAFETY INFORMATION	2
WARRANTY	3
OPERATING PRINCIPLES	3
Major Parts and Airflow Pattern.....	3
Use When Outdoor Air is Dry.....	4
Operating Position and Storage Position.....	4
Outdoor Air is Usually Cleaner	4
The Energy Exchange Core.....	5
Additional Building Heating/Cooling Costs	5
SETUP AND USE	6
Measure Indoor and Outdoor Conditions.....	6
Position the Dri-X.....	6
Attach Ducting	6
Place Pump Hose in a Drain	7
Connect to Power.....	7
Blowers and CFM.....	7
Automatic Defrost.....	8
ESTIMATING WATER REMOVAL	8
Examples by Geographical Area	9
SERVICE	11
SPECIFICATIONS	11
TROUBLESHOOTING	12

Congratulations on your selection of a new Dri-X Airchanger from Dri-Eaz Products Inc. It is our goal to offer you the highest quality system available. We invite your written appraisal and suggestions for improvements. Reading this Owner's Manual will help you achieve maximum benefit from your Dri-X.

SAFETY INFORMATION

Dri-Eaz is concerned about the safety of everyone who uses or comes in contact with the Airchanger. The unit is designed to be operated in compliance with the safety warnings and instructions provided in this manual. Like other electrical devices, the unit can become dangerous if it is abused, damaged or misused. Failure to observe the following warnings can result in injury to persons, fire danger or damage to the unit.

Safety Warnings

To reduce risk of electrical shock, fire, or personal injury, read and follow each of the warnings below.

Keep the Unit Grounded

The Dri-X Airchanger is designed to operate on ordinary household 115 volt, 60 Hertz alternating current and comes with a three pronged grounding

plug. Never remove or modify this three pronged plug. Do not use an ungrounded two pronged adapter. The grounding pin on the unit's plug is an essential safety feature that will help reduce the risk of shock or fire in the event of an electrical hazard.

Protect the Power Cord from Damage

Never operate the Airchanger with a damaged or frayed power cord or extension cord. Never unplug the unit by pulling the cord. Grasp the plug firmly and pull straight out. Do not close a door on the cord, or pull the cord over or around sharp corners or rough surfaces. Do not run equipment over the cord or use the cord as a handle. Keep the cord away from heated surfaces and out of standing water.

Danger

Removal or alteration of the grounding plug, or use of an adapter that defeats the Dri-X Airchanger's electrical grounding, can create risk of serious personal injury or fire in the event of damage to or malfunction of this product. Do not use the unit if you cannot connect it to a receptacle that accepts a three-pronged plug. If you are unsure whether a receptacle is grounded, consult a qualified electrician.

Keep Out of Water

Do not place the Airchanger in standing or running water. Never operate or store the unit outdoors or expose the unit to rain or water from overhead sources, such as leaking pipes or dripping ceilings. The Dri-X is not weather proof and water may drip into its electrical parts and cause risk of electrical shock or damage to the unit.

Caution

The Airchanger may be operated on a damp surface, but you should make sure that no water pools around the machine. If it does, do not operate the unit until the surface has dried sufficiently to eliminate pooling.

Electrical Components Must Be Dry

Never allow water inside the unit's electrical components. If these area become wet for any reason, thoroughly dry them before using the unit.

Keep Children Away

The Dri-X Airchanger is not a toy. Do not allow children to play with or around the unit. Be sure that the unit is inaccessible to children when left unattended. Children can hurt themselves or others by playing with or around a unit. Secure all rooms and buildings in which a unit is left unattended while running.

Secure Unit During Transport

When transporting in a vehicle, secure the Dri-X to prevent sliding and possible damage to the unit or injury to vehicle occupants.

Don't Modify Unit

Never modify the motor or wiring of the Dri-X.

Keep Air Intakes Unobstructed

Operate the Dri-X away from draperies and other materials that may come in contact with its air intakes. Always use a clean air filter.

Maintenance or Repair

Do not attempt to disassemble or repair the Dri-X Airchanger if you are not qualified to do so. Normal maintenance operations and troubleshooting solutions can be handled by the technician in the field. More complex problems should be handled by an authorized service technician. See the Troubleshooting section. For information about authorized repair and maintenance, call Dri-Eaz at (360) 757-7776.

Danger

Do not attempt to service or clean the Dri-X Airchanger while it is plugged into an electrical outlet. It is dangerous for an unqualified individual to attempt to disassemble or repair the unit.

LIMITED 1-YEAR WARRANTY

Limited Warranty: Dri-Eaz promises to the original purchaser to replace, at no charge, any part of the Dri-X Airchanger that proves to be defective in workmanship or materials for a period of one (1) year from date of purchase. During this period the customer is responsible for all freight and labor costs. After one year, the customer is responsible for all replacement parts, labor and freight costs to and from the service center.

To receive warranty parts: All replacement parts must be pre-authorized through our service center. Please direct questions on the warranty to an authorized distributor or Dri-Eaz Products, Inc.

Limitations: This warranty shall not extend to any products showing effects of misuse, disassembly, alteration, lack of proper maintenance, corrosive chemicals, improper voltage, accident damage, unauthorized repairs, use of other than authorized parts and materials, fire, flood, normal wear or any other causes beyond Dri-Eaz Products' control. The warranty obligation extends only to the replacement of parts found, upon Dri-Eaz Products' examination, to be defective. The foregoing constitutes the entire warranty and no other warranty, liability, contingency or responsibility, direct, indirect, consequential or in any way connected with the sale or operation of equipment products is expressed or implied.

OPERATING PRINCIPLES

The Dri-X Airchanger performs two functions that are useful for restorative drying and other applications.

First, it lowers the humidity to dehumidify the air. Ample dehumidification is a necessity when drying wet buildings and materials.

Major Parts and Airflow Pattern

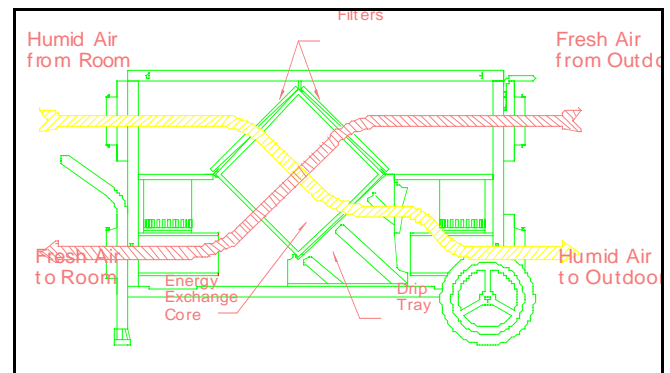

One airstream carries humidity and contamination harmlessly to the outdoors. The other airstream brings fresh, clean air from outdoors to replace it. Heating/cooling energy is saved by the Energy Exchange Core. Both airstreams are cleaned by filters before entering the Core. Moisture that may condense is caught in the drip tray and pumped to a drain.

Second, the Dri-X improves IAQ or indoor air quality. It does this by replacing humid, contaminated indoor air with dry, fresh, clean air from

outdoors. The unit achieves this benefit without causing security problems or excess energy loss.

Two airstreams pass through the Dri-X. They introduce outdoor air to the restoration environment, while at the same time expelling indoor air from the building.

One airstream takes air from a room and blows it outdoors. This airstream not only carries the excess humidity, it also exhausts pollutants including odors, mold spores, dust, allergens and pathogens. All are removed harmlessly to the outdoors.

Meanwhile, in the second airstream, dry, fresh, clean air from outside the room or building is pulled through the Dri-X in the other direction and blown into the room.

While passing through the Energy Exchange Core, the airstreams exchange heat, thus retaining the energy of the building's heating or air conditioning systems.

The difference between indoor and outdoor temperature and specific humidity conditions is measured in grains per pound (specific humidity). This difference determines the Dri-X's efficiency in reducing humidity. The greater the difference, the more effective the unit. That is, the drier the air outdoors, compared to the air indoors, the faster the Dri-X reduces indoor humidity and speeds the drying process.

Operating Position and Storage Position

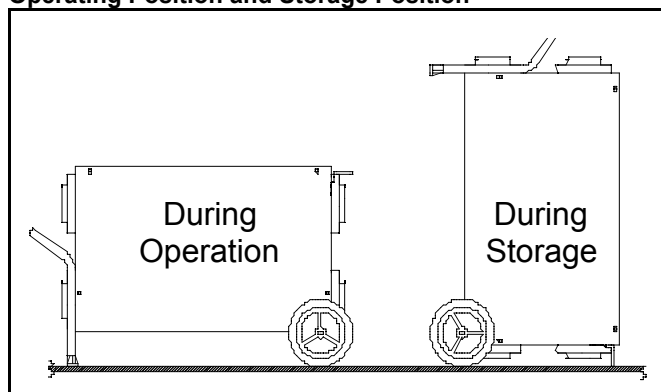

The Dri-X must always be *operated* in the horizontal position. It can be *transported or stored* in the upright position as shown.

When the air is much colder outdoors than indoors, and the indoor air is very humid, some of the outgoing moisture condenses in the Energy Exchange Core. This condensed water drains out

of the Core into the drip tray, where it collects and is pumped out. A 40-foot hose from the unit is placed in any convenient drain.

The amount of moisture being pumped out is only a small percentage of the water being removed from the room. A much greater amount is being removed as invisible water vapor in the airstream passing to the outdoors. You cannot judge the effectiveness of the Dri-X by measuring the water coming from the pump hose; you can only judge it by calculation. See the section on Estimating Water Removal.

Use When Outdoor Air is Dry

To know if the Dri-X Airchanger will efficiently remove humidity on any job, you must know that the outdoor air is actually drier than the indoor air. You can do this easily using a thermo-hygrometer, plus the Calculator provided with the Dri-X or a standard psychrometric chart.

Outdoor air is quite often drier than indoor air, especially in restorative drying situations. The section on Water Removal Rates will help you understand this fact. In many areas of the country, at many times, outdoor air is drier than the air indoors during a water damage situation with high indoor humidity.

When outdoor air is "wetter" than indoor air (again, as measured in grains per pound), the Dri-X should not be used because it would actually raise the indoor humidity. This would sometimes be the case in areas such as the South Atlantic and Gulf Coast states, or the Midwest in the summer on days of high humidity. When outdoor air is wetter, the Dri-X should be turned off.

When the specific humidity or grains per pound of the outdoor air and the indoor air are the same, no change in the indoor humidity will result. However, at these times the Dri-X can still be used to improve IAQ by exchanging the indoor and outdoor air.

Outdoor Air is Usually Cleaner

Indoor air quality in a water-damaged building can be uncomfortable and even unhealthy. Contaminants may include offensive odors activated and released by water, dust from moving furniture

or demolishing damaged structures, spores released into the air from mold and mildew growth, endotoxins from bacteria when unsanitary water is present, and other pollutants.

Even before a water damage, the air outdoors is almost always 2 to 5 times cleaner than the air indoors, according to the Environmental Protection Agency. An EPA publication states that "A growing body of scientific evidence has indicated that the air within homes and other buildings can be more seriously polluted than the outdoor air in even the largest and most industrialized cities." (*The Inside Story: A Guide to Indoor Air Quality*, IAQ-0009).

The Dri-X Airchanger exhausts not only the humidity in the air on a water damage job, but other contaminants as well. It expels them while bringing in outdoor air, which tends to be cleaner, fresher, healthier, and more comfortable.

The power of the Dri-X in cleaning the air can be judged by how many air changes it performs. The Dri-X replaces indoor air with outdoor air at a rate of over 250 CFM (cubic feet per minute) in a typical setup, or 15,000 cubic feet per hour.

The volume of air in a building with 1,875 square feet of floor space and 8-foot ceilings is 15,000 cubic feet. The Dri-X will change this volume of air about once every hour.

The Energy Exchange Core

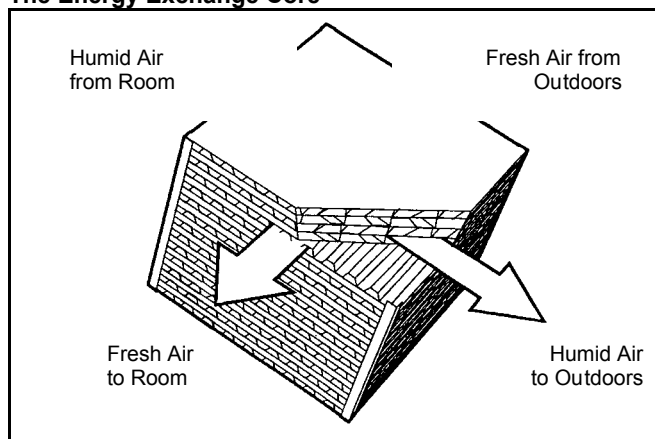

The Energy Exchange Core is constructed of corrugated aluminum panels laid alternately at 90° to each other. The two airstreams exchange thermal energy but do not mix.

Saving Heating/Cooling Energy

Cool or cold air from outdoors is almost always both drier and cleaner than indoor air on a water damage job. One might think it would be good to just open doors and windows and let the outside air in – that is, use an open drying system. However, this could compromise building security or might be unacceptable to the owner or adjuster.

Also, it would cost too much to heat large amounts of outdoor air with the building's heating system. (In the same way, warm or hot dry air from outdoors would be too costly to cool with an air-conditioning system.)

As the Dri-X Airchanger brings in outdoor air to replace indoor air, at the same time it saves most of the thermal energy of the building's heating or air-conditioning system. It does this by passing both airstreams through the Energy Exchange Core.

Warning

Do not allow any water inside the unit. If electrical components or wiring become wet, thoroughly dry before using. Do not unplug the unit while it is operating.

When indoor air is being warmed by the building's heating system, the heat energy passes to the incoming cooler air. When the indoor air is being cooled by the building's air-conditioning system, the heat in the outdoor air passes to the out-going air. In both cases, the thermal energy is retained.

The efficiency of the Energy Exchange Core is about 70%. That is, about 30% of the heating or cooling thermal energy is lost to the outdoors, and about 70% is saved. The approximate cost to a building owner using electric heating is shown in the table. The cost varies depending on how cold the outdoor air is, and the local cost of power.

Additional Building Heating/Cooling Costs (Daily)

Outside Temperature	Where Power Cost is 5c/kwh	Where Power Cost is 15c/kwh
50° F 10° C	\$ 0.57	\$ 1.71
40° F 4° C	\$ 0.85	\$ 2.56
30° F -1° C	\$ 1.14	\$ 3.42
20° F -7° C	\$ 1.42	\$ 4.27
10° F -12° C	\$ 1.71	\$ 5.13

0° F -18° C	\$ 1.99	\$ 5.98
-------------	---------	---------

protected due to possible minor leakage from the unit.

SETUP AND USE

Operate the Dri-X Airchanger in a room or building being dried in much the same way as a refrigerant or desiccant dehumidifier.

Measure Indoor and Outdoor Conditions

Using a thermo-hygrometer (like the DHT-200 or the DHT-600), read the temperature and the relative humidity both indoors and outdoors. Convert both sets of readings to grains per pound. The outdoor reading must be LOWER (fewer grains per pound) than the indoor reading. This means that the outdoor air is drier, and the Dri-X Airchanger will operate as designed.

To convert temperature and relative humidity to grains per pound (commonly called specific humidity or the humidity ratio), use the Dri-X Airchanger Water Removal Calculator included with the machine. You may also use any psychrometric chart, or the Dri-Eaz Psychrometric Calculator.

The drier the outdoor air is (fewer grains per pound), the faster the Dri-X will reduce indoor humidity. If the outdoor and indoor air grains per pound figures are equal, then outdoor and indoor air are equally dry – they hold the same amount of water vapor. In this case the Dri-X will continue to clean the indoor air, but will not dehumidify it. If the outdoor air is "wetter" (more grains per pound), the Dri-X will actually increase the indoor humidity, so it should not be used.

Position the Dri-X

Operate the unit in an enclosed area, with doors, windows, and other openings to the outside closed. However, open all interior doors throughout the area being dried.

Maintain good airflow with TurboDryers in the entire drying area. High-volume and high-velocity airflow will both raise the rate of evaporation, and help mix the air being drawn into the Dri-X and expelled to the outdoors.

Caution

When operating a DrizAir Airchanger on a hardwood floor, it is suggested that the floor surface be

The incoming airstream blows into the room from the lower vent on the end of the Dri-X with the large handle, marked "Fresh Air to Room." This airstream can be pointed toward especially wet areas. It can also be ducted to speed drying in other rooms or areas.

Humid air is drawn into the Airchanger from the room through the upper vent on the end of the unit with the large handle, marked "Humid Air From Room."

Keep all vents clear of any blockage or restriction of free airflow, for example from draperies.

Attach Ducting

The upper vent on the wheeled end of the Dri-X is marked "Fresh Air from Outdoors," and the lower vent on the same end is marked "Humid Air to Outdoors." These two vents must be attached by ducting to a source of outdoor air (see photo).

Attach 5-inch insulated ducting to the two vents. Reach into one end of the ducting, and pull out the inner duct made of vinyl with a wire core. Tuck the ends of the black plastic outer cover around the fiberglass insulation. Over this, slip one of the 5-inch hose clamps provided. Slide the assembly onto the vent and tighten the clamp.

Two 25-foot lengths of ducting are included with the unit. Equivalent additional ducting, common in HVAC applications, is available at hardware stores. Use insulated ducting to avoid sweating and condensation. (The colder the air outdoors is, the more that condensation may occur.)

Typical Installation



In a typical installation, the Dri-X Airchanger is connected to the outdoor air with 5-inch insulated ducting. For a secure system, an insert board is cut to fit the window. Additional duct rings are supplied to attach to the insert.

Use only enough ducting to reach conveniently from the Dri-X to a window or other source of outdoor air. Excess ducting will reduce the amount of airflow passing through.

Pass the end of the ducting through the window, and seal off the rest of the opening so that air can not leak in or out.

It may help to separate the vents to the outdoors as much as possible, preventing expelled air from being sucked back into the in-coming air. This effect will be minimized by the fact that the airstream being expelled is moving at a high rate of speed away from the outlet. Also, any breeze that is present will help disperse it.

To best protect building security, construct a window insert from plywood or stiff building board. Cut the panel to fit, and close the window securely on it. Secure the window with a board or dowel, or in the case of an aluminum-frame window, with a clamp from a hardware store. In the insert, cut two 5-inch holes with a saber-saw. Over these holes, bolt the two extra duct rings provided with the Dri-X. Secure the ends of the ducting to the duct rings with the hose clamps provided.

Danger

Do not under any circumstances remove the round grounding plug from the cord. To do so will increase the risk of personal injury, shock or fire.

Place Pump Hose in a Drain

The 40-foot pump hose is normally wrapped around the main handle when not in use. During operation, place the end of the hose in any convenient drain such as a sink or toilet.

The purpose of the pump is to remove any water that condenses in the Energy Exchange Core. While most of the water vapor in the indoor air is carried to the outdoors in the airstream, some may condense. It runs out of the Core into the drip-tray and is pumped away.

Condensation is greater when the outdoor air is colder, because the temperature of the out-going airstream may be lowered below its dew-point, causing the water vapor to condense out.

Run Unit Dry After Use

IMPORTANT! After completing operation, some water may remain in the Core. Remove the duct bringing in fresh air from the outdoors, then **let the unit run for 10 minutes** to pump away any remaining condensation. This will prevent leakage when the unit is moved.

Connect to Power

Plug the 20-foot cord into a standard 115-volt circuit. The unit draws less than six amps of power. When inserting or removing the plug, take precautions against electrical shock whenever floors or materials are wet.

If using an extension cord, use only a cord rated to deliver the appropriate voltage to the Dri-X. An extension cord up to 25 feet in length should have a wire gauge of a least 16 AWG. The rating of a 50-foot extension cord should be at least 14 AWG.

Blowers and CFM

The two airstreams in the Dri-X are driven by a pair of centrifugal blowers. The incoming airstream is measured at 325 CFM (cubic feet per minute) without ducting connected. With a normal ducting setup, the airflow is about 280 CFM. The

out-going airstream, somewhat constricted by its passage through the drip tray, is measured at 244 CFM with ducting.

Automatic Defrost

Extremely low outdoor temperatures may freeze water that has condensed in the Core. A probe is inserted into the Core. If it senses a freezing temperature it switches off the blower pulling air from the outdoors. During the shut-off period the other blower continues to run, forcing

room temperature air through the Core and melting the ice. The first blower will restart after the temperature in the Core rises to 35°F (1°C).

Caution

Before shutting off the Dri-X, remove ducting from the vent marked "Fresh Air from Outdoors." Then let the unit run 10 more minutes, to pump away any condensation and prevent leakage.

ESTIMATING WATER REMOVAL

The Dri-X can be very efficient as a dehumidifier. Its rate of water removal depends on how much drier the outdoor air is when compared to the indoor air. The Water Removal Chart below shows the unit's power. Using the chart allows comparing the rate of dehumidification to that of refrigerant or desiccant dehumidifiers. When justifying rental rates, the unit's value as an air cleaner should be added in.

To estimate the unit's removal of water from a humid indoor environment, use a thermo-hygrometer plus the Dri-X Airchanger Calculator, or a psychrometric chart, table or calculator and the Water Removal Chart below.

(Numbers given in the examples are accurate calculations. When using a psychrometric chart, numbers will be less exact. Use larger and more detailed charts for more precise estimates.)

Step 1.

Measure the temperature and the relative humidity both indoors and outdoors, using a thermo-hygrometer. *Example: You measure indoor conditions at 70°F (21°C) and 70% Rh. Outdoors, your readings are 59°F (15°C) and 40% Rh.*

Step 2.

Convert your readings into grains per pound using the Dri-X Airchanger Calculator, or a psychrometric chart or calculator. This figure is often called the specific humidity. *Example: Using the example above, the indoor condition is 77 gpp. The outdoor condition is 30 gpp.*

Step 3.

Subtract outdoor from indoor gpp. Look up this number on the bottom scale of the Water Removal Chart. Move up to the graph line, then left to gallons per day, or right to pints per day. *Example: In this case, the difference between indoor and outdoor conditions is 77 gpp less 30 gpp, or 47 gpp. (77 - 30 = 47.) Looking up 47 gpp on the graph, you find that the water removal is 166 pints or about 21 gallons per day.*

IMPORTANT: The outdoor gpp *must NOT be higher* than that of the indoors. This would mean that the outdoor air is more humid – it is holding

more water vapor. Do not use the Dri-X Airchanger in these conditions, because it will bring additional water vapor indoors, which would *raise* indoor humidity.

Water Removal Chart

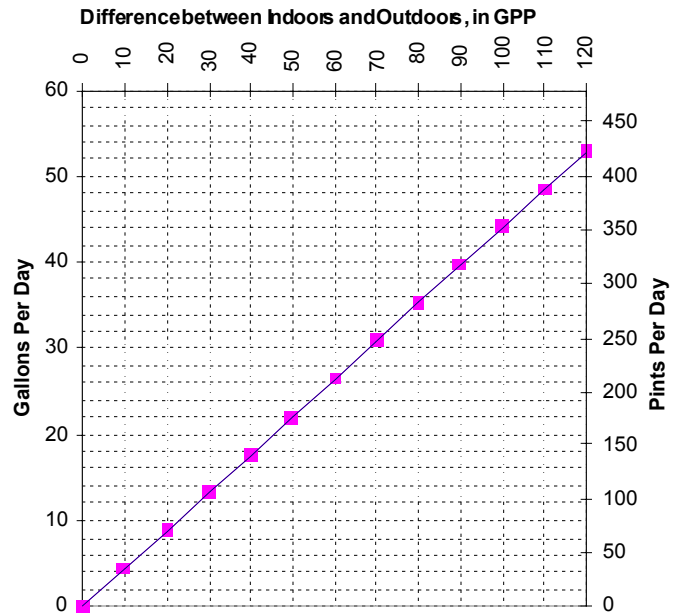

Examples by Geographical Areas

Example 1. During early stages of a job in Minneapolis during the winter, indoor conditions are 75°F and 85% Rh. From your calculator or chart you find that indoor specific humidity is 111 gpp (grains per pound). Outdoor conditions are 20°F (-4°C) and 25% Rh, for a specific humidity of about 4 gpp. The difference is 107 gpp (111-4=107). Reading from the Water Removal Chart, the Dri-X is removing 377 pints or 47 gallons per day.

Example 2. You're in Seattle. It's cool and foggy outdoors where your measurements are 48°F and 85% Rh, or 42 gpp. Indoor conditions are 70°F and 65% Rh, or 71 gpp. The outdoor air is drier by 29 gpp (71-42=29). Water removal is 102 pints or 13 gallons per day, similar to a large refrigerant dehumidifier used in the same room.

Example 3. In a Miami summer, the outdoor air is 85°F with 70% relative humidity. Thus it holds 128 gpp of water vapor. Indoor conditions are 70°F and 90% Rh, or 99 gpp. Don't be fooled

by the fact that the *relative humidity* outdoors is lower. The outdoor air is holding *more* moisture (128 gpp compared to 99 gpp indoors). Do not use the Airchanger in this situation. Use the unit only where the outdoor air is *drier* than the indoor air, that is, when outdoor gpp or *specific humidity* is lower.

Example 4. Assume that in a Phoenix summer, your 24-hour average outdoor conditions are 75°F and 22% Rh, or 28 gpp. Indoors your measurements are 70°F and 55% Rh, or 60 gpp. The difference is 32 gpp, so the water removal is about 113 pints or 14 gallons per day.

The following table should help determine whether the general weather conditions are suit-

able for using the Dri-X. Please note that these figures apply **ONLY** at the indoor conditions given. For other indoor temperature and/or humidity conditions, use the Water Removal Chart above or the Dri-X Airchanger Calculator.

Danger
Removal or alteration of the grounding plug, or use of an adapter that defeats the unit's electrical grounding, can create risk of serious personal injury or fire in the event of damage to or malfunction of this product. Do not use the Dri-X Airchanger if you cannot connect it to a receptacle that accepts a three-pronged plug. If you are unsure whether a receptacle is grounded, consult a qualified electrician.

WATER REMOVAL AT STANDARD INDOOR CONDITIONS

Removal at indoor conditions of 70°F (21°C) and 70% Rh

OUTDOOR TEMPERATURE		OUTDOOR HUMIDITY				
		100% Rh	80% Rh	60% Rh	40% Rh	20% Rh
Fahrenheit	Centigrade	WATER REMOVAL IN GALLONS PER DAY				
0 ° F	-18 ° C	31	32	32	33	33
20 ° F	-7 ° C	27	28	30	31	33
32 ° F	0 ° C	22	25	27	29	32
40 ° F	4 ° C	18	21	24	28	31
50 ° F	10 ° C	11	15	20	25	29
60 ° F	16 ° C	0	7	14	20	27
70 ° F	21 ° C	-15	-5	5	15	24
80 ° F	27 ° C	-35	-21	-7	7	21
100 ° F	38 ° C	-99	-71	-44	-17	9

Gray areas indicate negative humidity reduction – turn off unit during these conditions.

Removal at indoor conditions of 80°F (27°C) and 60% Rh

0 ° F	-18 ° C	37	38	38	39	40
40 ° F	4 ° C	25	28	31	34	37
80 ° F	27 ° C	-28	-14	0	14	27

SERVICE

Cleaning the Filters

Each airstream passes through a filter just before entering the Energy Exchange core. The filter catches and holds particulate matter, and is treated to be resistant to fungus growth.

Clean the filters periodically. Remove either side panel (four 5/16"-head bolts screwing into permanently attached nuts) and pull the filters away from the Velcro fastenings. Vacuum them, blow them out with compressed air, or wash them with water. Use a little detergent if needed.

Danger

Do not attempt to service or clean the Airchanger while it is plugged into an electrical outlet. It is dangerous for an unqualified individual to attempt to disassemble or repair the unit.

Cleaning the Energy Exchange Core

Inspect the Energy Exchange Core regularly. If it becomes dirty it can be cleaned.

IMPORTANT! Before removing the Core from the Dri-X, *remove the defrost control sensor*

wire probe from the core. After removing the filter on the "Humid Air from Room" side, you will see that the wire is inserted into one of the aluminum corrugations. Pull it straight out of the Core and leave it bent to one side. Replace it in the same spot after cleaning the Core. When removing or replacing the probe, be careful not to damage the corrugations.

To remove the Energy Exchange Core, after removing either side panel and removing the defrost control sensor probe, slide the Core straight out. There is a handle on one end to assist in removal. Clean with the soft brush attachment of a vacuum cleaner. You can blow out the Core with compressed air or the air output from a shop-vac, being careful not to damage the corrugations.

Warning

Before removing the Energy Exchange Core from the Dri-X, carefully remove the defrost control probe according to directions. Failure to do so may cause damage to the Core.

SPECIFICATIONS

Item	Specification	
Power	7.0 amps – 115 volts, 60 hz	
Use Weight	132 lbs.	60 kg
Shipping Weight	179 lbs.	74 kg
Height x Weight x Depth	27 x 24 x 46 inches 67 x 61 x 117 cm	
In-coming Airflow (no ducting)	325 cfm	9.2 m ³ /min
Out-going Airflow (no ducting)	304 cfm	8.6 m ³ /min
In-coming Airflow (12' of ducting)	280 cfm	7.9 m ³ /min
Out-going Airflow (12' of ducting)	244 cfm	6.9 m ³ /min
Defrost	Thermostatic	
Power Cord	20 ft.	6.1 m
Pump Hose	40 ft.	12.2 m

Specifications are subject to change without notice. Some values are approximate.

TROUBLESHOOTING

Caution

Troubleshooting solutions fall into two categories listed in the third column. Field Solutions (FS) are those procedures that can be handled by the technician in the field. Others solutions should be handled by a repair technician and are listed as Authorized Service Technician (AST).

WARNING: All the service procedures below should be executed with power off i.e. unplugged.

PROBLEM	CAUSE	SOLUTION
The unit does not operate	1. No power to blowers	FS 1. Check power at outlet, be sure switch is on.
Dri-X is operating but room is not dry	1. Not enough time passed for materials to dry	FS 1. Allow more time for drying
	2. Poor air movement	FS 2. Increase air movement with Dri-Eaz TurboDryers
	3. Excessive air infiltration	FS 3. Reduce unwanted airflow into the area being dried
	4. More humid outdoors	FS 4. Operate only when outdoor specific humidity is lower than indoor
	5. Filters are restricted.	FS 5. Clean filters.
Little water is flowing through the pump tube	1. Most water vapor escapes in airstream unless outdoor air is cold	FS 1. Check outdoor temperature; if not very much colder, there is no problem
	2. Air movement through unit restricted	FS 2. Check filters and ducting for free airflow
	3. Failed pump or pump tube.	FS 3. Replace pump or pump tube.

**FOR PARTS AND SERVICE CALL YOUR LOCAL DISTRIBUTOR,
OR THE DRI-EAZ SERVICE DEPARTMENT AT (360) 757-7776**