

**SERVICE MANUAL  
PARTS LIST**

**BURNISHER**

***MODELS:***

**B-1500 FP**

**SERVICE**

## INDEX

	PAGE
I.- FINAL TEST PRODUCT SAFETY	3
II.- REPLACEMENT PROCEDURES ASSEMBLY	3
III.- TROUBLE SHOOTING CHART	5
IV.- ELECTRICAL RATING	6
V.- WIRING DIAGRAM	6
VI.- PART LIST	7
VII.- ASSEMBLY	9

## I. FINAL TEST FOR PRODUCT SAFETY

AT THE COMPLETION OF ANY REPAIR THE PRODUCT SHOULD BE ELECTRICALLY TESTED FOR OPERATING AND ELECTRIC TEST AS FOLLOWS

### ELECTRIC TEST

- A). - Set hi-pot meter at 1500 V
- B): -Place Switch Lock to on position.
- c). -Touch one probes of tester to on blade of power cord plug and touch other probe to handle tube. There should be no breakdown.

### OPERATING TEST

RUN THE MACHINE ON HARD SURFACE WITH BRUSH OR PAD AND MAKE SURE:

- A). - THERE IS NO UNUSUAL NOISE OR VIBRATION
- B). - THE MOTOR STARTS FAST AND WITH OUT NOISE
- C). - THE CURRENT DRAW IS LESS THAN 15 AMP.

## II. - REPLACEMENT PROCEDURES ASSEMBLY

### 1. - INDUCTION MOTOR ASSEMBLY REPLACEMENT ( 112 )

- 1.1. - Disconnect the line cord ( 46) from the motor line cord ( 108)
- 1.2. - Place the burnished in vertical position. Unscrew the center driver ( 218) counterclockwise the three screws (216) as well as the base fix ( 218)
- 1.3. -Remove the six screws ( 214 ) the flex base ( 212) the five screws (196) five washers ( 194 ) and the plate (192-A)
- 1.4. - Loosen the four screws ( 204 ) pull the motor from the pulley disc ( 180 ) remove the belt
- 1.5. - Remove the Allen screw (208 ) the motor pulley ( 210) as well as the locking pin (206) place the burnished in normal position and remove the handle tube assembly.
- 1.6.-Remove the three screws (116) lift the motor cover ( 104 ) remove the connection box from the motor, and disconnect the three leads of the motor line cord assembly ( 108 ) also removing the motor cover ( 104 )
- 1.7.- Remove the molding motor cover ( 110 ) four screws (122 ) the two capacitor covers (124 ) the two capacitor insulators ( 120 ) disconnect the two capacitors ( 118 and 126 )
- 1.8.- Place the burnisher in position down, remove the four screws ( 204 ) the washer ( 202 ) as well as the four washers ( 200 )
- 1.9.- Remove the assembly chassis ( 166 ) only the motor ( 112 ) that is assembly cover motor ( 104 ) as well as the molding motor cover ( 110 )
- 1.10.- Replace the motor assembly and reassemble

**NOTE : When replacing the motor ,make sure the replace has same characteristics it's also important the two capacitors to place and connect the capacitors as initially placed to avoid damaging the motor and alignment from pulleys .**

### 2..-TO REPLACED BELT ( 198 )

- 2.1.- Follow steps indicated on point 1-2,1-3 and 1-4
- 2.2.- Replace belt and reassemble alignments from pulleys

### **3.- PULLEY AXLE REPLACEMENT ( 172 )**

- 3.1.- Follow steps 1-2,1-3, and 1-4.
- 3.2.- Remove the elastic bolt ( 188 ) pressure washer ( 190 ) and flat washer ( 186 )
- 3.3.- Remove the pulley flex disc ( 180 ) which is assembled with two bearings ( 182 ) the bearing separator ( 184 ) and clamp ( 178 )
- 3.4.- Remove the four bolts ( 176 ) pressure washer ( 174 ) remove the pulley axle and reassemble.

**NOTE : Pulley axle ( 172 ) and chassis ( 166 ) bolt holes can be assembled one way only, therefore if the bolt holes are not aligned when attaching the pulley axle to the chassis ,rotate the pulley axle until the holes are aligned and allow the four screws ( 168 ) to pass freely**

### **4.- BEARING REPLACEMENT ( 182 )**

- 4.1.- Follow steps 1-2,1-3 and 1-4.
- 4.2.- Follow steps 3-2, and 3-3
- 4.3.- Remove the clamp ( 178 ) the two bearings ( 182 ) as well as the bearing separator.
- 4.4.- Replace the two bearings, and reassemble.

### **5.-ON-OFF HANDLE REPLACEMENT ( 38 )**

- 5.1.- Remove the two screw ( 10 ) and two washers ( 12 )
- 5.2.- Remove the screw ( 4-A ) and sure button ( 4-B ).
- 5.3.- Remove the switch box cover black ( 8 )
- 5.4.- Remove the two bolts with head ( 16 ) and two springs ( 40 )
- 5.5.- Replace the ON-OFF handle, and reassemble.

### **6.- MICRO SWITCH REPLACEMENT ( 34 )**

- 6.1.- Follow Steps 5-1,5-2 and 5-3
- 6.2.- Disconnect her connection micro switch
- 6.3.- Remove the two screw ( 30 ) and two washers ( 32 )
- 6.4.- Remove and replace the micro switch and switch insulator ( 36 ) as originally assembled.

### **7.- ASSEMBLY SURE REPLACEMENT ( 4 )**

- 7.1.- Follow steps 5-1,5-2 and 5-3.
- 7.2.- Remove the dust cover ( 4-G ) and two screws ( 4-F)
- 7.3.- Remove the assembly sure and replace the component damaged and reassemble

### **8.- LINE CORD ASSEMBLY REPLACEMENT**

- 8.1.- Follow steps 5-1,5-2 and 5-3 .
- 8.2.- Disconnect the ground ( green ) as well as the lead connected to micro switch ( 34 ) and the cable switch assembly ( 22 ) connect to the thermal protector ( 24 )
- 8.3.- With Heyco pliers, remove the grommet ( 50 ) and washer ( 48 ) remove the motor lead assembly ( 32 ) as well as the grommet line tube ( 35 )
- 8.4.- Replace the motor lead by inserting the handle assembly ( 14 ) upwards and previously placing the grommet tube ( 60 )
- 8.5.- Place the washer ( 34 ) as well as the grommet ( 50 ) at the same distance as the prior lead ,connect and reassemble as initially placed.

### **9.- LINE CORD REPLACEMENT ( 56 )**

- 9.1.-Follow steps 5-1,5-2 and 5-3.

9.2.- Disconnect ground (green ) as well as connection micro switch ( 34 ) and the connect to thermal protector (24)

9.3.-Remove the nut from the effort relief assembly ( 52 )

9.4.- Replace line cord ,connect and reassemble as initially placed

**WHEN ORDERING ,DO NOT FORGET TO SPECIFY :**

- ✓ **PART NUMBER**
- ✓ **DESCRIPTION**
- ✓ **MODEL NUMBER**

**NOTE: Drawing numbers are for identification purposes only.**

**III.- TROUBLE SHOOTING CHART**

**1.MOTOR DOES NOT START**

POSSIBLE CAUSE	SOLUTION
NOT PLUGGED IN PROPERLY	CHECK CONNECTION
LINE CORD DAMAGED	REPLACE
MICRO SWITCH DAMAGED	REPLACE MICROSWITCH
CIRCUIT BREAKER OFF	RESET BREAKER
CAPACITOR DAMAGED	REPLACE CAPACITOR
MOTOR LINE CORD DAMAGED	REPLACE MOTOR LINE CORD
MOTOR ASSEMBLY DAMAGED	REPLACE MOTOR ASSEMBLY
PISTON AND SPRING DAMAGED	REPLACE

**2..-MOTOR WORKS BADLY**

POSSIBLE CAUSE	SOLUTION
LOW VOLTAGE	CHECK VOLTAGE ( LINE )
CAPACITOR DAMAGED	REPLACE CAPACITOR
IMPROPER MOTOR CONNECTIONS	CHECK CONNECTION

**3. MOTOR STARTS ,DOES NOT RUN DRIVER**

POSSIBLE CAUSE	SOLUTION
BELT DAMAGED	REPLACE BELT
MOTOR PULLEY DAMAGED	REPLACE MOTOR PULLEY
PULLEY AXLE DAMAGED	REPLACE PULLEY AXLE

**4.-MOTOR NOISY**

POSSIBLE CAUSE	SOLUTION
BEARING DAMAGED	REPLACE BEARING

#### IV. ELECTRICAL RATING /

120 V ~

60 Hz

15 A

#### V .-WIRING DIAGRAM

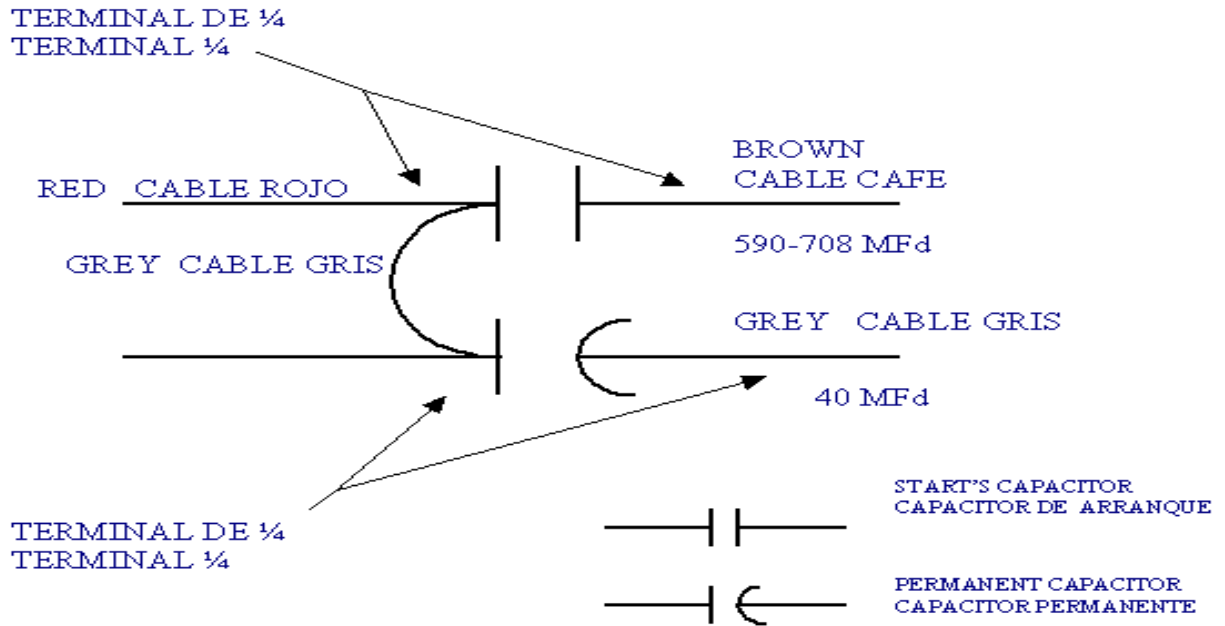

## VI.-PART LIST

ITEM	PART No	DESCRIPTION	PZAS
2	12-0830-5	Handle Tube Upper	2
4	45-0534-3	Kit spare assembly lock	1
4-A	01-0272-3	screw # 6 x 1/2 "	1
4-B	13-2209-8	Sure Button	1
4-C	13-2205-6	Piston of the Insurance	1
4-D	13-2206-4	Sure	1
4-E	13-2208-0	It Covers Box it Guides of The Insurance	1
4-F	01-1732-5	screw # 8-32 x 1/2 "	2
4-G	37-0225-5	Dust Cover	1
4-H	05-3536-9	Tubular Separator	2
4-I	24-0292-3	Spring	1
4-J	13-2207-2	Box Guides of the Insurance	1
6	17-3783-2	Switch Box Label Burnisher	1
8	05-3975-9	Switch Box Cover Black	1
10	01-1984-2	Screw # 8-32 x 1"	2
12	04-0276-8	Star Washer # 8	2
14	23-0733-8	Assemble Handle for Switch	1
16	03-0593-8	Bolt with Head	2
18	01-1256-5	Screw Phillips 10-24 x 3/4	2
20	17-3677-6	Label " Reset "	1
22	28-0958-0	Switch Assembly Wire	1
24	38-0338-4	Thermal Protector 20A	1
26	04-0271-9	Star Washer # 10	2
28	02-0015-4	Hexagonal Nut 10-24	2
30	01-0851-4	Screw Hex. # 6-32 x 1"	2
32	04-0275-0	Star washer # 6	2
34	11-0096-5	Micro Switch	1
36	08-1857-5	Insulator Switch	1
38	05-3979-1	Stator lever	1
40	24-0292-3	Spring	2
42	01-0852-2	Screw Hex # 8-32 x 3/8 "	1
44	04-0493-9	Star Washer # 8	1
46	28-0672-7	Motor Cable / Contac Assembly	1
48	04-0036-6	Washer	1
50	12-0414-8	Grommet Heyco 0.062	1
52	45-0456-9	Cord Strain Relief	1
54	10-0140-3	Connector of Pressure 2 x 14	1
56	28-1078-6	Line Cord Assembly	1
58	01-1724-2	Allen Screw 5/16-24 x 3/4	1
60	12-0115-1	Grommet of Rubber	1
62	06-0486-8	Hook Cord	1
64	02-0092-3	Elastic nut 1/4-20	2
66	01-1769-7	Screw Hex. # 1/4 -20 x 1 1/2 "	2
102	17-3036-5	Motor Cover Insert	1
104	05-3765-4	Cover Motor	1
106	12-0414-8	Grommet Heyco 0.062	1
108	28-0671-9	Motor Cable / Contac Assembly	1
110	12-0692-9	Molding Motor Cover	2
112	00-1736-8	Motor Induction	1
114	02-0071-7	Nut Fastener	3
116	01-0068-5	Screw # 8 x 3/8 "	3

ITEM	PART No	DESCRIPTION	PZAS
118	15-0678-1	Capacitor 40 MFd	1
120	08-0979-8	Insulator Capacitor	2
122	01-1093-2	Screw Hexagonal # 8 x 3/8 "	4
124	05-3567-4	Capacitor Cover	2
126	15-0013-1	Capacitor 590-708 MFd	1
128	12-0024-5	Grommet	2
130	23-0615-7	Cover Motor Assembly	1
132	46-2231-2	Lever Tube Adjustment Assembly	1
132-A	12-0617-6	Lever Grip	1
134	05-3582-3	Washer	1
136	06-0404-1	Clamp tube	1
138	04-0073-9	Flat Washer 3/8 "	1
140	45-0451-0	Joint Turning knob	1
142	25-0155-9	Axis yoke	1
144	06-0771-3	Industrial Polishing yoke	1
146	04-0352-7	Lock Ring	2
148	01-1012-2	Allen Screw 3/8-16 x 3/8 "	1
150	03-0119-2	U Rivet	2
152	17-3550-5	"Precaution " Plate	1
154	04-0074-7	Flat Washer 1/2 "	2
156	05-43041	Tense Tube	2
158	25-1319-0	Separator of the Brace	2
160	45-0396-7	Wheel Assembly	2
162	01-1704-4	Screw Hex 1/2-13 x 3 "	4
164	45-0496-5	Wheel Assembly	2
166	06-0884-4	Chassis " FP"	1
168	01-1745-7	Screw Cab Car 5/16-18 x 1 "	4
170	17-3025-8	Insert "KOBLENZ "	1
172	06-0757-2	Pulley Axle	1
174	04-0144-8	Pressure Washer 5/16 "	4
176	02-0024-6	Nut Hex 5/16-18	4
178	04-0521-7	Lock Ring	1
180	06-0758-0	Disc Pulley	1
182	26-0187-0	Bearing 6204	2
184	04-0522-5	Spacer	1
186	04-0567-0	Flat Washer Pulley Axle	1
188	02-0136-8	Security Nut 5/8-18	1
190	04-0154-7	Pressure Washer 5/8	1
192	46-2745-1	Kit spare plate/Gasket	1
192-A	23-0665-2	Assy. Plate Burnisher	1
192-B	12-0809-9	Assy. Plate Gasket	1
194	04-0078-8	Pressure Washer 1/4 "	5
196	01-1775-4	Screw Hex. 1/4-20 x 3/4 "	5
198	12-0715-8	Belt	1
200	04-0366-7	Flat Washer 3/8 "	4
202	04-0142-2	Pressure Washer 3/8 "	4
204	01-1774-7	Screw Cab Car 3/8-16 x 1 1/4 "	4
206	25-0021-3	Locking Pin	1
208	01-1012-2	Allen Screw 3/8 -16 x 3/8 "	1
210	06-0869-5	Motor Pulley	1
212	46-2319-5	Flex Base	1
214	01-1077-5	Screw Hexagonal. 1/4-20 x 1 "	6
216	01-0069-3	Screw # 8 x 1/2 "	3
218	13-1978-9	Pad Holder	1



# X.- ASSEMBLY

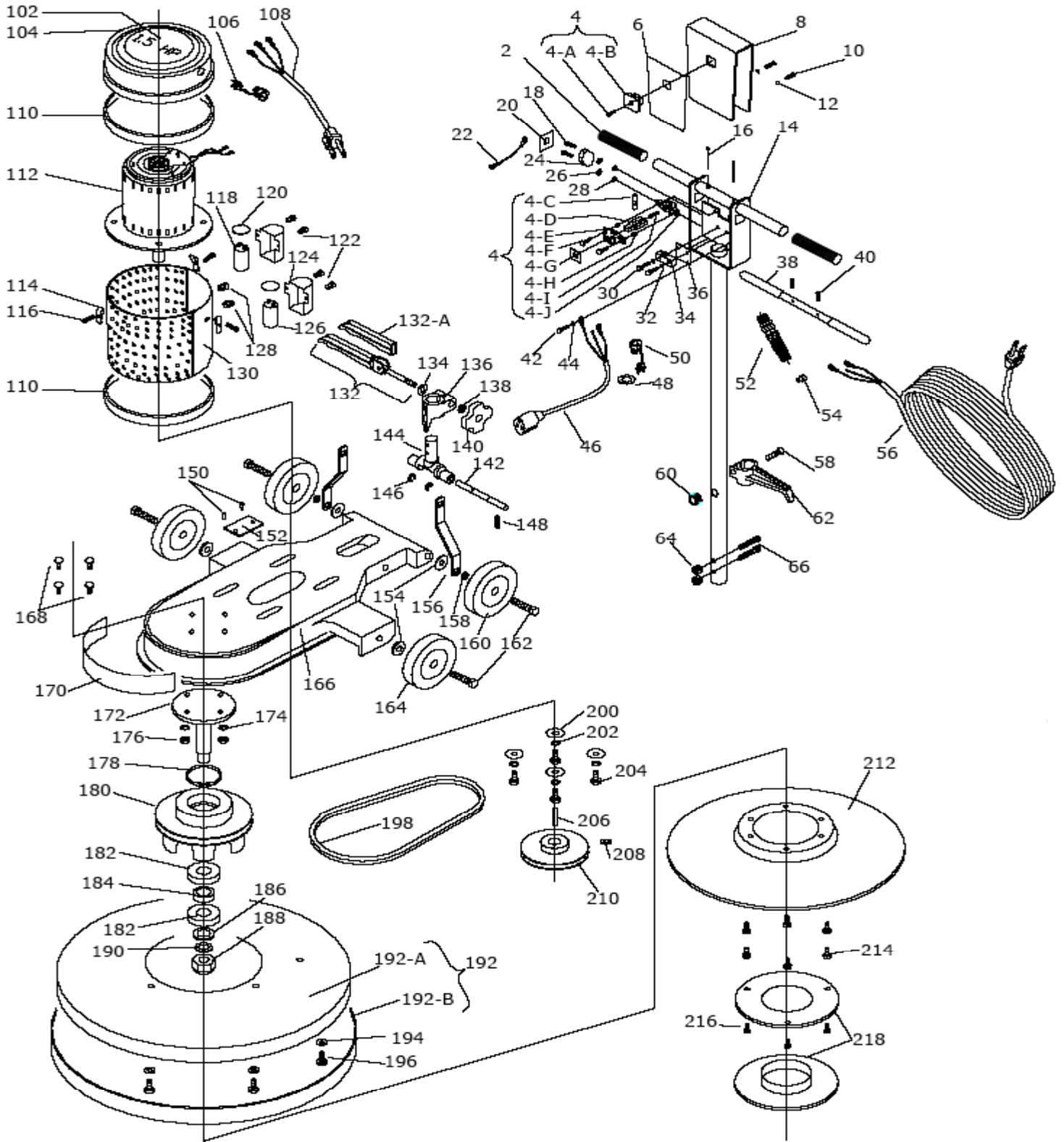



**FACTORY AUTHORIZED SERVICE**

Thorne Electric Company  
610 Lanark Suite 205  
San Antonio TX ,78218  
Tel (210) 590-1226  
Fax (210) 590-1258  
1-800-548-5741

**FACTORY**

Koblenz Electrica ,S.A. de C.V.  
Av. . Ciencia No 28 Cuautitlán Izcalli  
Edo. de México ,C.P. 54730  
Tel : 5864-0300  
Web site : <http://www.koblenz.electric.com>

**KOBLENZ ELECTRICA S.A. DE C.V.**  
E-mail: [servicio@koblenz-electric.com](mailto:servicio@koblenz-electric.com)

LP-APVI500-200509

**SERVICE**