



**SERVICE MANUAL
PARTS LIST**

SHAMPOO POLISHER

MODELS:

**P-1800
P-2500 A
P-2600**

SERVICE

INDEX

	PAGE
I.- FINAL TEST FOR PRODUCT SAFETY	3
II.- REPLACEMENT PROCEDURES	3
III.- TROUBLE SHOOTING CHART	6
IV.- ELECTRICAL RATING	7
V.- WIRING DIAGRAM	8
VI.- SCHEMATIC EXTERNAL MACHINE PARTS	9
VII.- EXTERNAL MACHINE PARTS LIST	10
VIII.- SCHEMATIC INTERNAL PARTS	12
IX.- INTERNAL MACHINE PARTS LIST	13

I. - FINAL TEST FOR PRODUCT SAFETY

AT THE COMPLETION OF ANY REPAIR THE PRODUCT SHOULD BE ELECTRICALLY TESTED FOR RUNNING AND ELECTRIC STRENGTH AS FOLLOWS

ELECTRIC TEST

- A). - Set hi-pot meter at 1500 V
- B). -Product Switch to on position.
- C). -Touch one probes of tester to on blade of power cord plug and touch other probe to handle tube. There should be no breakdown.

RUNNING

RUN THE MACHINE WITHOUT BRUSHES (FREE RUNNING) AND CHECK :

- A) . -There should be no unusual noise or vibration.
- B) . -The carbon brushes spark should be small and uniform
- C) . – The current shall bi no more than 1.5 A
- D) .- Run the machine with scrubbing brushes on the floor ,the current shall be 3.0 A

II. - REPLACEMENT PROCEDURES ASSEMBLY

1. TO REPLACED A FIELD (67) OR ARMATURE (63)

- 1.1.-Disconnected elbow hose connector (51) from tray assembly (95)
- 1.2.- Remove cover (35) by removing four cover screws (93)
- 1.3.-Pull open the connector on the motor cable (24)
- 1.4.- Remove the connector support (87) with the connector block (75)
- 1.5.-Remove gear cover plate screws (61) from both sides along with cover plates and gaskets (84-85-86)
- 1.6.-Remove the four motor covers screws (61-99) and the motor cover (60)
- 1.7.-Remove the bearing clamp screws (68) from both sides along with the bearing clamps (69)
- 1.8.- Remove the carbon brush holder assembly (62)
- 1.9.-Remove the field support screws (64) and field supports (65-66)
- 1.10.-To replace the field , the connector block (75) must be removed , push the retaining tab of each terminal with a pin and release it by pulling it pulling it out .
- 1.11.-The field (67) and armature (63) may now be lifted out replacement .

2.- TO REASSEMBLE

- 2.1.-Position the armature in the field so that the armature commutator is on the same side as the field leads
- 2.2.-Position an armature bearing package (70-71-72-74) on each end of the armature shaft so that the rectangular projection on the seal is facing the armature winding and is between the bearing and armature .
- 2.3.-Position the armature (63) and the field (67) in the motor frame (88) making sure the leads side of the field (67) are placed close to the bottom windows in the motor frame (88) witch are next to the carbon brush holder (62) .
- 2.4.-The armature bearing and seals on the armature (63) ate positioned in their respective places in the motor frame (88) making sure the two straight sides on the boss of the bearings are in the vertical position.
- 2.5.-Hold the field position replacing the fields supports (65,66) and screws (64)
- 2.6.-Replace the carbon brush holder (62) and carbon brushes .
- 2.7.-Make sure that armature thrust plates and the armature thrust balls are in position on the ends of the armature shaft.
- 2.8.- Replace armature bearing clamps (69) on top of the armature bearing ,with screws (68)
- 2.9.-Adjust endplay by adding thin plates until there is 0.005"-0.010" clearance between the armatures thrust plate on the fan end of the unit .measured by a feeler gage.
- 2.10.-Replace the cover plates ,gaskets and screws (84-85-86) and (61) .
- 2.11.-place the block (75i), n the detent connector (75) , and push close the connector on motor cable (24) .
- 2.12.- Place the unit into the cover (35) and secure with the four cover screws (93) .
- 2.13.-Reconnect the elbow hose connector (51) into the tray (95)

3 .- TO REPLACE GEAR (77 OR 78) OR A SPINDLES (79)

- 3.1.- Remove the four cover screws (93) separate the base plate (92) and motor assembly from cover (35)
- 3.2.-Pull open the connector on motor cable (24)
- 3.3.- Remove the motor cable bushing with the motor cable (25)
- 3.4.-Remove the connector support (87) with connector block (75) ,now the motor assembly may be worked on more easily.
- 3.5.-Remove the spindle brush drive pin (96D) by driving it out with a cylindrical punch of suitable diameter and remove the pin insulator (96 E)
- 3.6.-Remove the spindle cap insulator (96A) pressing the tab (96 C) and pulling the cap out .
- 3.7.- Remove the caps from the tree screw insulators (94) by prying them of with a screw driver placed opposite the strap tab on the part and remove the three motor frame holding screws (93)
- 3.8.-Remove the base plate (92) from the motor assembly .
- 3.9.-Remove frame insulators (83) ,spindle retainers (82) and washers (81)
- 3.10.-Remove the gear case cobber plate screws (61) ,the cover plates and the cover plate gaskets (84-85-86) and the motor cover (60) ,this provides access to gearboxes.
- 3.11.-The gears (77 or 78) or spindle (79) may now be removed by lightly tapping the bottom of the spindle.
- 3.12.-Remove the spindle nuts (76) the gears (77 or 78) and their keys (80)
- 3.13.-The gearboxes should be cleaned of all foreign material and old grease .
- 3.14.-Inpesct the condition of the armature shaft (63) and gears (77-78) ,if they are damaged ,replace them .
- 3.15.-The gears may be replaced by aligning the slot in the gear with the slot in the new or old spindle and reinserting the key (80) making sure the gear shoulder is placed below in contact with the motor frame and the gear (77 or 78) is leaning on the nut (76) .
- 3.16.-Position the gear (77 or 78) assembled to the spindle (79) in the motor frame (88) and replaces the washers (81) spindle retainer (82) and frame insulators (83) , the axial play of the spindle should be less than 0.10" .

- 3.17.-The gear boxes should be regressed with the grease provided in the bag together with the gears ,making sure all the grease is used ,the most of it applied in the contact zone of the gears
- 3.18.-Reassembly cover plates ,cover plate gaskets (84-85-86),motor cover (60) and screws (61-92) on reverse order used for disassembly .
- 3.19.-Replace the connector support (87) with the connector block (75) .
- 3.20.-Replace the motor cable bushing and push close the connector ion motor cable (24)
- 3.21.-Reassemble the motor assembly to the base plate (92) in a reverse order used for disassembly ,making sure the frame spacers (83) and motor supports (90) are well positioned.

4.-TO REPLACE GEARS (77 OR 78) OR SPINDLES (102-103) (ONLY MODELS WITH 8 SLOTS DRIVE)

- 4.1.- Follow steps 3.1 to 3.4
- 4.2.-Follow steps 3.10
- 4.3.-Follow 3.12
- 4.4.-Remove the spindles (102-103) by lightly tapping the top of the spindle inside the gear case
- 4.5.-Follow steps 3.13
- 4.6.-Inspect the condition of the armature shaft and gears ,if they are damaged ,replace them .
- 4.7.-Insert the new spindles from bottom of motor frame and replace the gears aligning the slot in the gear with the slot on the spindle ,and reinserting the key (80) making sure gear shoulder is placed below in contact with the motor frame, and replace the nut (76) .
- 4.8.-Follow steps 3.17 or 3.20
- 4.9.-Reassemble the motor assembly on the cover in reverse order used for disassembly

5.-TO REPLACE THE CARBON BRUSHES

- 5.1.- Follow steps 1.1,1.2,1.3,1.4,1.6,1.8
- 5.2.-Replace the carbon brushes and reassembles.

6.-TO REPLACE

- 6.1.-Remove four covers screws (93) and remove base plate (92) from the cover (35)
- 6.2.-Pull open the connector on motor cable (24) .
- 6.3.-Remove the motor cable bushing.
- 6.4.-Remove the switch box retaining screw (6)
- 6.5.-Remove the switch box (5) from tube (2) .
- 6.6.-Remove the switch cover screws (4) and open the cover (9)
- 6.7.-Disconnect the motor cable (24) from the switch (8) inserting a round needle of 1.5 mm diameter into the switch hole of each wire and pulling out the wire .

7 .-TO REPLACE A LINE CORD (23)

- 7.1.- Follow steps 6.4,6.5 y 6.6.
- 7.2.-Disconnected the line cord (23) from the switch (8) inserting a round pointed needle of 1.5 mm diameter into the switch hole of each wire and pulling out the wire .
- 7.3.-after replacement is an accomplished ,the line cord (23) must be reassemble in exactly the same manner as it was prior to disassembly.
- 7.4.- Follow steps 6.9 and 6.10.

8 .-TO REPLACE THE SWITCH (8) .

- 8.1.-Remove the switch box retaining screw (6)
- 8.2.-Remove switch box (5) from handle tube (2) .
- 8.3.-Remove the switch cover screws (4) and open the cover (9)
- 8.4.-The switch (8) is held in position by the switch box cover and can now be removed .
- 8.5.-Disconncetd switch (8) from line cord (23) and the motor (24) inserting a round pointed needle of 1.5 mm diameter into the switch ho of each wire and pilling out the wire ,replace it with a new switch making sure that wires are replaced on the same position as they were prior to removal .
- 8.6.-Place the switch on the box and replace the cover (9) ,the screws (4) and the knob (11) .
- 8.7.-Reassemble the switch on the box in the handle and secure with box retaining screw (6) .

9 .-TO REPLACE A FAULTY BRUSH SPINDLE INSULATOR (96 A) (ONLY MODELS WITH DRIVE PINS)

- 9.1.-Remove the spindle drive pin (96 D) by driving it out with a cylindrical punch of suitable diameter and remove the pin insulator (96 E)
- 9.2.-Remove the spindle cap insulator (96 A) by pressing the tab (96 C) and pulling the cap insulator out .
- 9.3.-Assemble the spindle insulator (96-E) is aligned .
- 9.4.-Reassemble the brush drive pin so that equal it is exposed on either side of the spindle insulator (96 E)

10 .-TO REPLACE A 8 SLOTS BRUSH DRIVE COUPLE (106 OR 107 A) (ONLY ON MODELS WITH 8 SLOT DRIVE)

- 10.1.-Turnt the machine with the brush side facing up.
- 10.2.-Insert a pair of brushes on the 8 slot couples.
- 10.3.-Hold the left brush (black couple) and turn the right brush C.C.W. until the couple unscrew and came out of the spindle
- 10.4.-Replace the new right couple (yellow) turning it C.W. on the spindle ,while holding the other brush .
- 10.5.-Remove and replace the left couple (black) on similar way turning it C.W. to loosening and C.C.W. to tighten.

11 .-TO REPLACE A MOTOR FRAME (88 OR A BASE PLATE) (92)

- 11.1.-Follow steps 1.1,1.2,1.3,3.2,3.2.3,3.5,3.6,3.7 and separate the base plate from the motor frame.
- 11.2.-Remove the screws (98) ,the washers (97) and the tray (95) .
- 11.3.-Base plate may now be replaced.
- 11.4.-To replace the motor frame ,follow steps 3.4,3.9,3.10,3.11.
- 11.5.-Remove four screws (64) and field supports (65-66) .
- 11.6.-Disconnect field wires from brush holder support (62) and remove it,
- 11.7.-Remove screws (68) and bearing clamps (69) .
- 11.8.-Remove push plates (73-74) and thrust balls (72) .
- 11.9.-Remove the field (67) and armature assembly (63) from the motor frame.
- 11.10.-The motor frame may now be replaced.
- 11.11.-For assembly of base plate (92) or motor frame (88) the steps are followed in reverse order.

III.- TROUBLE SHOOTING CHART

PROBLEM	POSSIBLE CAUSE	SOLUTION
1) Shampooed / Polisher does not run	A) Defective Switch. B) Defective power cord. C) Defective internal wiring. D) Motor failure. E) Worn carbon brushes	Replace switch . Replace power cord. Check wire connection at switch ,check motor cord check armature and held and replace armature and/ or field. Replace carbon brushes.
2) Excessive arcing	A) Dirt build up in motor B) Bad armature C) Worn carbon brushes	Blow with clean air Replace armature Replace carbon brushes .
3) Cleaning Brush does not run	A) Broken or missing drive pin .	Replace drive pin.
	B) Gear failure .	Replace gear
4) Handle and yoke assembly does remain in " up " position	A) Worn or broken yoke spring	Replace yoke spring
5) Cleaning brush does not lock on spindle cap	A) Defective spindle cap or brush retainer	Replace spindle cap or retainer
6) Cleaning brush does not lock on coupling.	A) Defective coupling	Replace coupling .

WHEN ORDERING ,DO NOT FORGET TO SPECIFY :

- ✓ **PART NUMBER**
- ✓ **DESCRIPTION**
- ✓ **MODEL NUMBER**

NOTE: Drawing numbers are for identification purposes only.

IV.- ELECTRICAL RATING

V~
120

A
4.2

Hz
50/60

V.- WIRING DIAGRAM

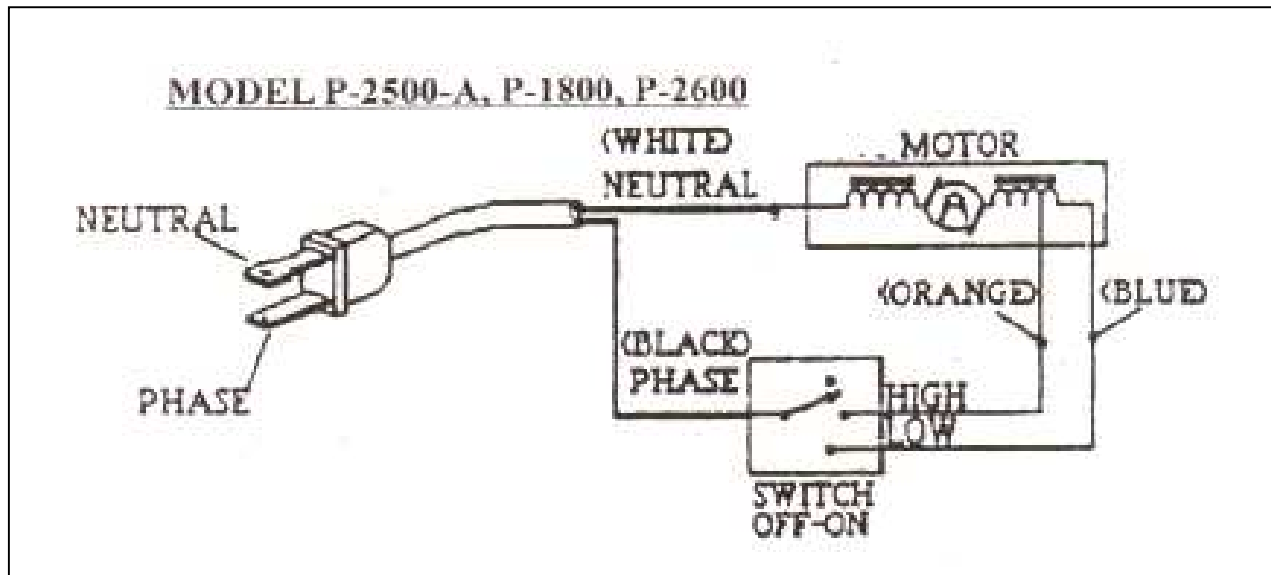

VI.- SCHEMATIC EXTERNAL PARTS LIST

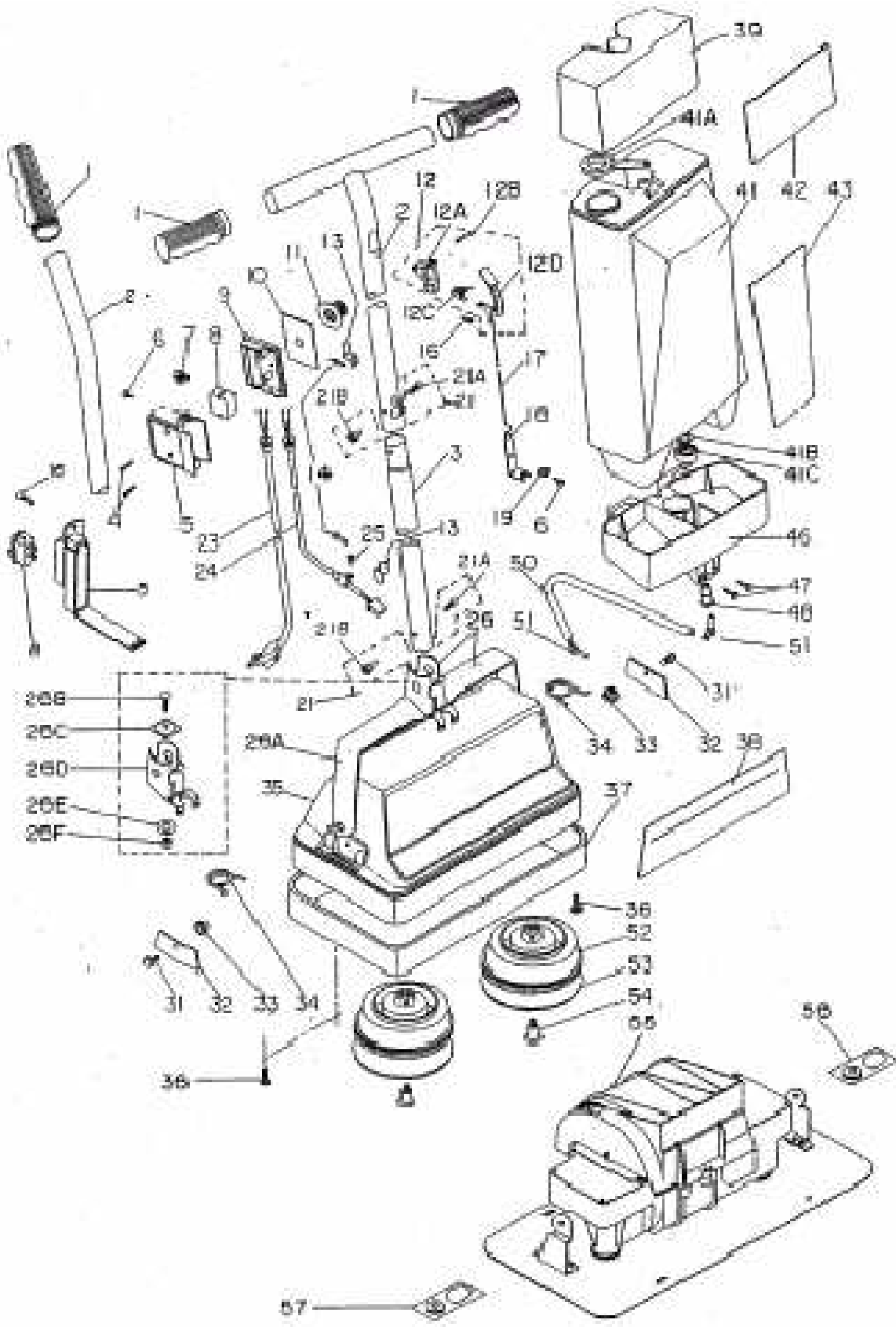

VII.- EXTERNAL MACHINE PARTS LIST

No.	PART. No.	DESCRIPTION	P-1800	P-2500-A	P-2600
1	13-0947-5	HANDLE GRIP	2	2	2
2	23-0391-5	UPPER HANDLE TUBE CHROMED	1		
2	23-0257-8	UPPER HANDLE TUBE			1
2	23-0705-6	UPPER HANDLE TUBE BLUE		1	
3	05-3040-2	LOWER HANDLE TUBE (CHROME)	1		
3	05-2710-1	LOWER HANDLE TUBE CHROMED			1
3	05-3686-2	LOWER HANDLE TUBE BLUE		1	
4	01-0536-1	SELF-TAPPING SCREW #6-20	2	2	2
5	13-0950-9	BLACK SWITCH BOX	1	1	1
6	01-0154-3	SELF-TAPPING SCREW #6X5/16		3	2
7	10-0042-1	P. NOZZLE WIRE CONNECTOR	1	1	1
8	11-0082-5	2-SPEED SWITCH	1	1	1
9	13-0951-7	BLACK SWITCH BOX COVER	1	1	1
10	17-2085-3	BOX LABEL 2 SPEED	1		1
10	17-4090-1	BOX LABEL 2 SPEED		1	
11	13-0952-5	BLACK SWITCH KNOB	1	1	1
12	46-1865-8	POLISHER LEVER		1	1
12-A	06-0463-7	CONTROL LEVER SUPPORT		1	1
12-B	25-0661-6	SPIRAL PIN 3/32		1	1
12-C	24-0158-6	VALVE SPRING			1
12-C	24-0098-4	VALVE SPRING		1	
12-D	06-0464-5	DISPENSER			1
12-D	06-0868-7	DISPENSER PAINTED		1	
13	05-0482-9	CHROME CORD HOOK	2		
14	03-0208-3	RIVET 5/32 X 1/4	2		
16	01-0062-8	SELF-TAPPING SCREW #6-20		1	1
17	09-0811-1	DISPENSING ROD		1	1
18	05-2197-1	VALVE HOOK		1	1
19	05-2223-5	VALVE HOOK SPACER		1	1
21	45-0330-6	HANDLE SCREW & NUT PACKAGE	2	2	2
21-A	01-0747-4	SCREW #10-32	2	2	2
21-B	02-0067-5	USE 02-0141-8	2	2	2
23	10-0099-1	POWER CORD, BLACK	1	1	1
24	28-0300-5	3-SPEED CABLE ASSEMBLY	1	1	1
25	01-0063-6	SCREW 6 X 1/2	1	1	1
26	23-0155-4	YOKE-SOCKET CHROMED ASSEMBLY	1		
26	23-0156-2	CHROME YOKE SOCKET ASSY.			1
26	23-0157-0	PAINTED YOKE SOCKET ASSY.		1	
26-A	05-3294-5	CHROMED YOKE	1		1
26-A	05-3295-2	GRAY YOKE		1	
26-B	01-1431-4	SCREW	1	1	1
26-C	05-2379-5	PLATE SOCKET	1	1	1
26-D	05-2886-9	SOCKET (CHROME)	1		
26-D	05-2392-8	GREY SOCKET		1	

No.	PART. No.	DESCRIPTION	P-1800	P-2500-A	P-2600
26-D	05-3190-5	SOCKET			1
26-E	05-0420-2	CONCAVE WASHER	1	1	1
26-F	02-0092-3	SECURITY NUT	1	1	1
31	01-0883-7	HEX SCREW 1/4-20	2	2	2
32	05-3297-8	YOKE SPRING COVER CHROMED	2		2
32	05-3298-6	YOKE SPRING COVER, GREY		2	
33	25-1072-5	YOKE SPACER	2	2	2
34	24-0258-4	EXTERIOR YOKE SPRING	2	2	2
35	06-0700-2	POLISHER COVER	1		1
35	06-0701-0	DIE CAST COVER, PAINTED		1	
36	01-1483-5	SELF-TAPPING SCREW #6 X 3/8	2	2	2
37	12-0457-7	FURNITURE GUARD	1	1	1
38	17-2001-0	HEAD LABEL	1		
38	17-2002-8	HOUSING LABEL			1
38	17-4088-5	HEAD LABEL		1	
39	13-0949-1	BLACK CONTAINER TOP			1
39	13-2590-1	CONTAINER TOP LABEL		1	
41	45-0015-3	120 OZ. TANK ASSEMBLY		1	
41	45-0140-9	144 OZ. TANK ASSEMBLY			1
41-A	13-0064-9	TANK CAP		1	1
41-B	04-0136-4	WASHER VALVE SPRING CUP		1	1
41-C	13-0068-0	VALVE CAP		1	1
42	17-2004-4	TANK TOP LABEL			1
43	17-2042-4	TANK LABEL			1
43	17-4089-3	TANK LABEL		1	
46	13-0948-6	CONTAINER BASE BLACK			1
46	13-2588-5	CONTAINER BASE BLUE		1	
47	01-1093-2	SELF-TAPPING SCREW		2	2
48	12-0694-5	CONTAINER BASE SEAL		1	1
50	13-0076-3	HOSE		1	1
51	13-0065-6	ELBOW HOSE CONNECTOR		2	2
52	45-0092-2	SHAMPOO BRUSH		2	2
52	45-0093-0	SCRUB BRUSH	2	2	2
53	37-0024-2	NYLON SCRUBBING PAD	2		2
53	37-0094-5	TAN POLISHING PAD	2	2	2
53	37-0095-2	LAN WOOL HIGH LUSTER PAD	2	2	2
54	13-0141-5	PAD RETAINER	2	2	2
55	46-1997-9	MOTOR ASSEMBLY 2 SPEED	1	1	1
56	46-1717-1	RIGHT GEAR W/GREASE	1	1	1
57	46-1718-9	LEFT GEAR W/GREASE	1	1	1

VIII . SCHEMATIC MACHINE INTERNAL PARTS

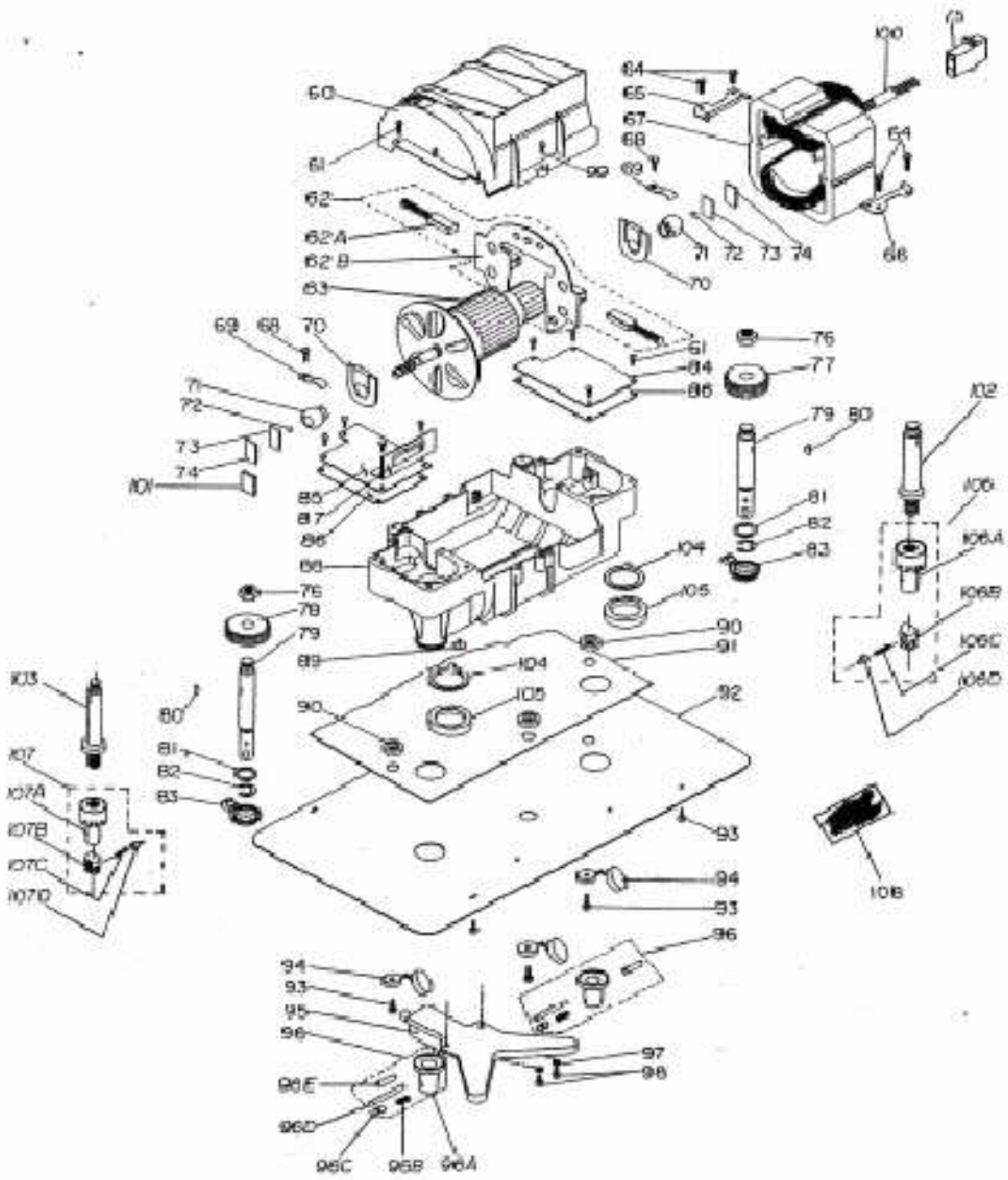

IX,- INTERNAL MACHINE PARTS LIST

No.	PART. No.	DESCRIPTION	P-1800	P-2500	P-2600
60	13-1418-6	MOTOR COVER	1	1	1
61	01-1483-5	SELF-TAPPING SCREW #6 X 3/8	10	10	10
62	28-0324-5	BRUSH HOLDER ASS	1	1	1
62-A	46-0104-3	CARBON BRUSH & SPRING	1	1	1
62-B	46-0590-3	BRUSH HOLDER	1	1	1
63	28-0263-5	ARMATURE	1	1	1
64	01-1489-2	SCREW #8 X 1 1/2	4	4	4
65	05-2862-0	FIELD SUPPORT	1	1	1
66	05-2864-6	FRONT FIELD SUPPORT	1	1	1
67	28-0308-8	2-SPEED FIELD	1	1	1
68	01-1490-0	SCREW	2	2	2
69	05-0607-1	BEARING CLAMP	2	2	2
70	12-0133-4	ARMATURE BEARING SEAL	2	2	2
71	26-0026-0	ARMATURE BEARING	2	2	2
72	26-0001-3	BALL ARM SHAFT/R - 30465P2	2	2	2
73	25-0059-3	THICK PUSH PLATE	2	2	2
74	25-0060-1	THIN PUSH PLATE	4	4	4
75	10-0051-2	CONNECTOR BLOCK 3 SPEED	1	1	1
76	02-0016-2	SPINDLE NUT	2	2	2
77	46-1717-1	RIGHT GEAR W/GREASE	1	1	1
78	46-1718-9	LEFT GEAR W/GREASE	1	1	1
79	25-1024-6	SPINDLE	2	2	2
80	25-0988-3	GEAR SPINDLE KEY	2	2	2
81	04-0018-4	WASHER .500 X .685	4	4	4
82	04-0238-8	SPINDLE RETAINER	2	2	2
83	13-1956-5	FRAME INSULATOR	2	2	2
84	23-0462-4	GEAR CASE COVER	1	1	1
85	23-0461-6	GEAR CASE COVER	1	1	1
86	37-0133-1	GASKET GEAR COVER	2	2	2
87	05-2718-4	SUPPORT 3 SPEED BLOCKS	1	1	1
88	23-0330-3	MOTOR FRAME ASSEMBLY	1	1	1
89	13-0059-9	FRAME SPACER	1	1	1
90	13-1040-8	MOTOR SUPPORT	3	3	3
91	13-0758-6	BASE INSULATOR	1	1	1
92	05-3374-5	BASE PLATE	1	1	1
93	01-1489-2	SCREW #8 X 1 1/2	7	7	7
94	13-0551-5	SCREW INSULATOR	3	3	3
95	13-0216-5	TRAY		1	1
96	46-1610-8	SPINDLE CAP INSULATOR PKG.	2	2	2
96-A	13-1038-2	SPINDLE CAP	2	2	2
96-B	24-0225-3	BRUSH LOCK SPRING	2	2	2
96-C	13-1039-0	LATCH NIB	2	2	2
96-D	25-0415-7	SPIRAL PIN 5/32 X 1	2	2	2
96-E	13-1135-6	BOLT INSULATOR	2	2	2
97	04-0002-8	WASHER .156 X .375		2	2
98	01-0154-3	SELF-TAPPING SCREW #6X5/16		2	2
99	01-0066-9	SCREW 6 X 7/8	1	1	1
100	08-1458-2	FIELD SLEEVE	1	1	1
101	25-1063-4	THRUST PLATE	1	1	1
108	46-2069-6	GREASE	2	2	2



FACTORY AUTHORIZED SERVICE

Thorne Electric Company
610 Lanark Suite 205
San Antonio TX ,78218
Tel (210) 590-1226
Fax (210) 590-1258
1-800-548-5741

FACTORY

Koblenz Electrica ,S.A. de C.V.
Av. . Ciencia No 28 Cuautitlán Izcalli
Edo. de México ,C.P. 54730
Tel : 5864-0300
Web site : <http://www.koblenz.electric.com>

KOBLENZ ELECTRICA S.A. DE C.V.
E-mail: servicio@koblenz-electric.com

LP-P1800-200611

SERVICE