



**SERVICE MANUAL
PARTS LIST**

UPRIGHT VACUUM CLEANER

MODEL:

U-75

KOBLENZ ELECTRICA, S. A. DE C. V.
e-mail: thorne_scsm@koblenz-electric.com

S
E
R
V
I
C
E

LP U-75

INDEX

	PAG
I. FINAL TEST FOR PRODUCT SAFETY	3
II. REPLACEMENT PROCEDURES	3
III. TROUBLE SHOOTING CHART	5
IV. WIRING ELECTRICAL	6
V. ELECTRICAL RATING	6
VI. UPRIGHT VACUUM CLEANER EXTERNAL PARTS	7
VII. UPRIGHT VACUUM CLEANER EXTERNAL PARTS LIST	8
VIII. UPRIGHT VACUUM CLEANER INTERNAL PARTS	9
IX. UPRIGHT VACUUM CLEANER INTERNAL PARTS LIST	10

I.- FINAL TEST FOR PRODUCT SAFETY

At the completion of any repairs the product should be electrically tested for operating and electric strength as follows.

1.-Electric test:

- 1).-Set hi-pot test meter at 1500 volts.
- 2).-Lower product handle to "ON" position
- 3).-Place one probe of the tester to one blade of the power cord plug and place the other probe to the handle tube, there should be no breakdown.

2.-OPERATING TEST

Run the machine with the height adjustment knob on high and check:

- 1).-There should be no abnormal noise or vibration.
- 2).-The carbon brushes spark should be small and uniform.
- 3).-The current should not exceed 7.0 Amps.

II.- REPLACEMENT PROCEDURES

1.-REPLACEMENT OF THE BAG

- 1.1 Remove the bag by releasing the spring on top, and turning the knob that holds the bag coupling in the lower part of the upright

2.-TO REPLACE THE TUBE HANDLE (2 AND 9)

- 2.1 Pull out the line cord from the cord retainer (5)
- 2.2 Remove the nut and screw (15 and 7) and pull out the tube

3.-REPLACEMENT OF BELT (49)

- 3.1 Turn the upright upwards
- 3.2 Remove the bottom plate (23) and the fan cover by pressing and releasing one side of the retaining shaft (22)
- 3.3 Pull and twist the belt over the pulley to remove it.
- 3.4 Pull the brush roll (21) from the ends to take it out of the chassis.
- 3.5 First, place the new belt on the brush roll, then place the brush roll in the chassis, put the belt on the pulley verifying that the belt is in the right position. Finally, assemble the fan cover and bottom plate.

4.-REPLACEMENT OF THE BRUSH ROLL (22) OR THE BEARING SUPPORTS (21)

- 4.1 Follow the steps indicated in item number 3.1 to 3.4
- 4.2 Remove the supports by pulling them out
- 4.3 Replace the new brush roll as indicated in item number 3.5

5.-REPLACEMENT OF THE REAR WHEELS (5)

- 5.1 Remove the cover (2) as described in procedure number 7
- 5.2 Pull out the padlocks (6) of the axis of the wheel (41) and remove the wheels.
- 5.3 Replace the new wheels by placing the washers (9), the wheels as well as the padlocks.
- 5.4 Place the cover back in position

6. REPLACEMENT OF THE FRONT WHEELS (11)

- 6.1 Remove the cover (2) as described in procedure number 7
- 6.2 Remove the screws (7) from the front axle retainer and the front axle spring (10)
- 6.3 Take out the front axle with the wheels
- 6.4 Remove the old wheels and place the new wheels
- 6.5 Replace the axle, the retainers and the spring
- 6.6 Place the cover back in position fix font size.

7. TO REMOVE THE COVER (2)

- 7.1 Remove the bag assy as described in procedure number 1
- 7.2 Release and lower the handle (39) to a horizontal position
- 7.3 Pull out the height adjustment knob (1)
- 7.4 Turn around the upright been careful not to scratch the cover
- 7.5 Use a flat end screwdriver to release the staples of the cover hood in the chassis (18)

8. REPLACEMENT OF THE MOTOR (51)

- 8.1 Remove the belt as described in procedure number 3
- 8.2 Remove the cover as described in procedure number 7
- 8.3 Remove the screws in the base of the motor (4) disconnect the switch cables and remove the motor.

9. REPLACEMENT OF THE HEIGHT CONTROL ADJUSTMENT LEVER (15)

- 9.1 Remove the cover (2) as described in procedure number 7
- 9.2 Remove the lever
- 9.3 Place the new lever in position

10. REPLACEMENT OF THE RELEASE HANDLE PEDAL (39)

- 10.1 Remove the cover (2) as described in procedure number 7
- 10.2 Remove the spring (40) from the chassis
- 10.3 Pull out the pedal

11.-REPLACEMENT OF THE YOKE (29)

- 11.1 Remove the cover (2) as described in procedure number 7
- 11.2 Remove the handle pedal as described in procedure number 10
- 11.3 Remove the yoke shaft (31) and the lock (20)

12. REPLACEMENT OF THE LINE CORD ASSY (25)

- 12.1 Unplug the line cord form the electricity
- 12.2 Follow the steps described in procedure number 7 (cover replacement)
- 12.3 Remove the grounded green cable
- 12.4 Disconnect both ends of the cable
- 12.5 Remove the Grommet (26) using a HEYCO clamp
- 12.6 Install the new line cord assy, placing the grommet at the same distance and connecting as it was initially

13. REPLACEMENT OF THE FRONTAL MOLDING (19)

- 13.1 Remove the screws (16)
- 13.2 Remove the molding and install the new one

14. REPLACEMENT OF THE SWITCH ACTUATOR (50)

- 14.1 Remove the cover (2) as described in procedure number 7
- 14.2 Follow the steps described in procedure number 11
- 14.3 Replace the new switch actuator and reassemble

III.- TROUBLE SHOOTING CHART

PROBLEM	POSSIBLE CAUSE	SOLUTION
A) Motor does not run	1.-Not firmly plugged in. 2.-Bad ON-OFF switch. 3.-Bad line cord. 4.-Bad Motor. 5.-Fan blockage by material.	1.-Check attachment plug. 2.-Replace switch. 3.-Replace cord. 4.-Check motor and wiring. 5.-Remove obstruction.
B) Motor runs but cleaner does not pick-up	1.-Broken belt. 2.-Air system blockage. 3.-Broken fan. 4.-Worn brush roll. 5.-Slow motor. 6.-Full bag.	1.-Replace belt. 2.-Replace obstruction. 3.-Replace fan. 4.-Replace brush rolls. 5.-Check motor. 6.-Empty bag (or change paper bag).
C) Brush roll vibrates	1.-Ball bearing worn out. 2.-Ball bearing holder damaged.	1.-Replace brush rolls. 2.-Replace ball bearing holder.

WHEN ORDERING, DO NOT FORGET TO SPECIFY:

- ✓ PART NUMBER
- ✓ DESCRIPTION
- ✓ MODEL NUMBER

NOTE: Drawing numbers are for identification purposes only

IV.- WIRING DIAGRAM

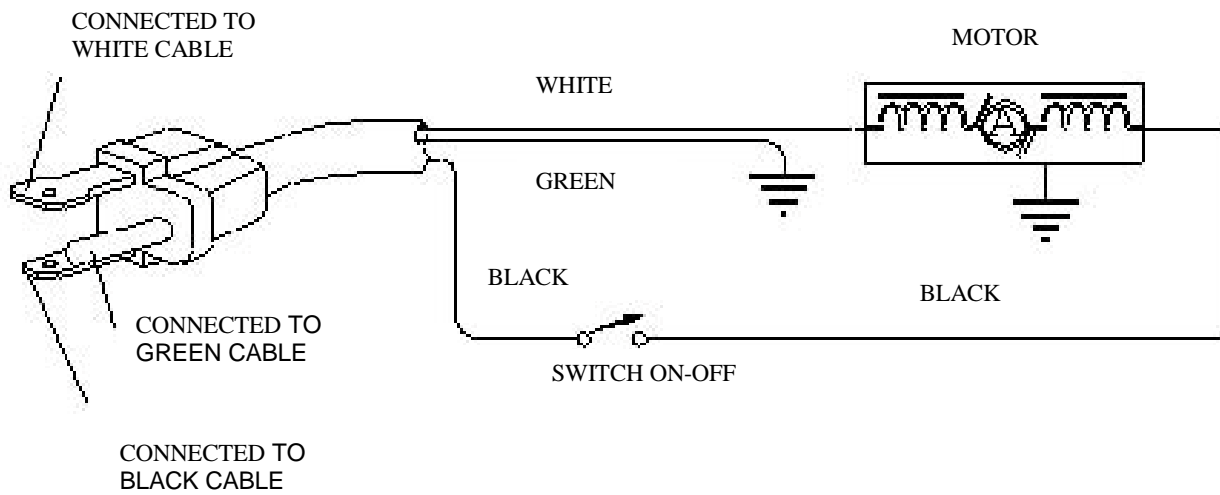

V.- ELECTRICAL RATING

7,0 A

120 V

60 Hz

VI.- UPRIGHT VACUUM CLEANER EXTERNAL PARTS

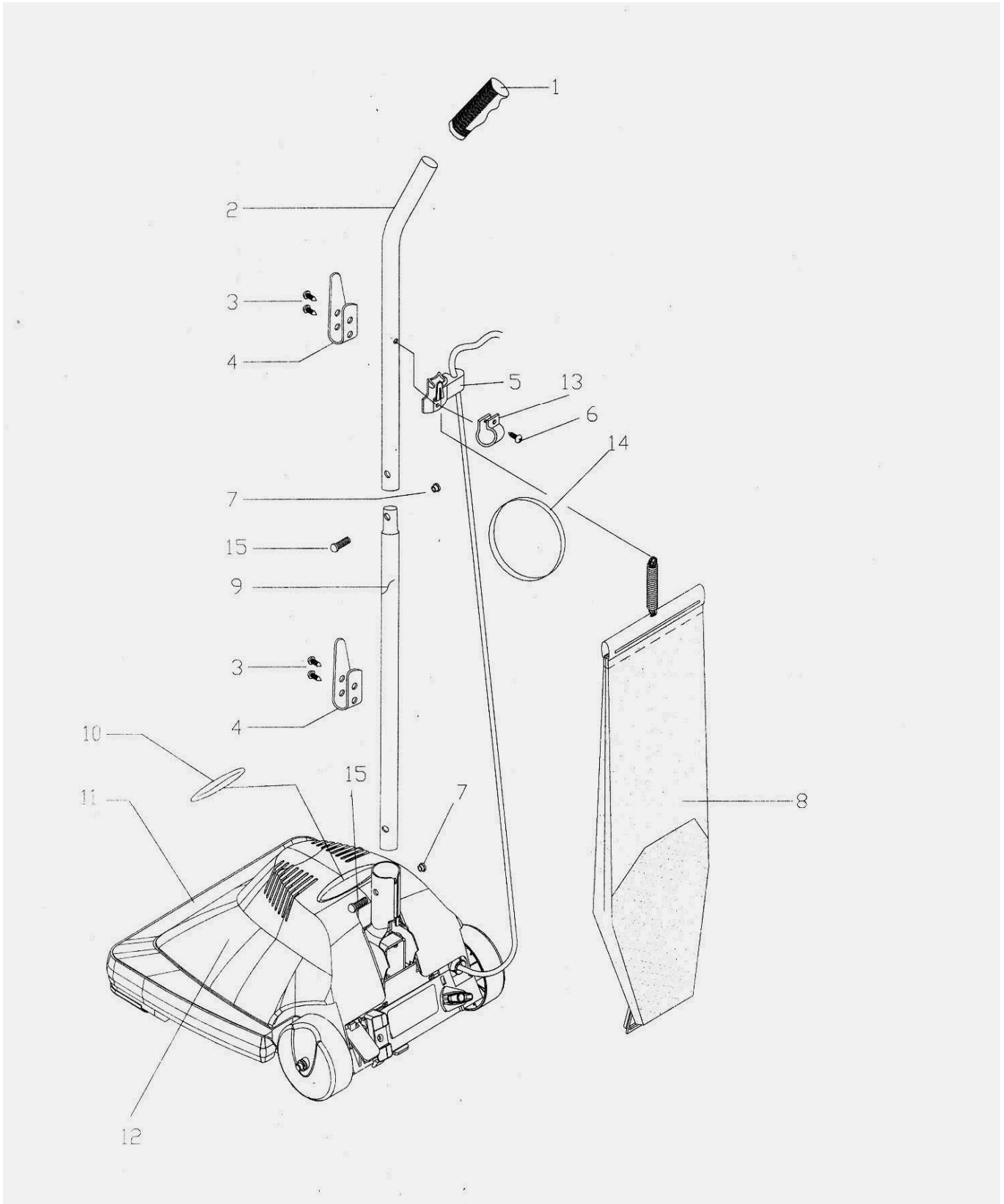

VII.-UPRIGHT VACUUM CLEANER EXTERNAL PART LIST

NO.	PART NUMBER	DESCRIPTION	U-75
1	13-0947-5	HANDLE GRIP	1
2	05-4091-01-2	UPPER HANDLE BLACK	1
3	01-0290-5	SCREW 10 X 3/8	4
4	05-4089-01-6	CORD HOOK BLACK U-75	2
5	13-1462-4	CORD RETAINER	1
6	01-0283-0	SCREW 8 X ½	1
7	02-0141-8	LOCK NYLON NUT 10-32	2
8	46-3231-1	BLACK DUMP BAG ASSY U-75	1
9	05-4090-01-4	LOWER HANDLE BLACK	1
10	17-4777-3	LABEL U-75 COVER	1
11	13-2883-0	POLYCARBONATE CHASSIS	1
12	13-2949-9	PLASTIC COVER U-75	1
13	13-0304-9	BELT RETAINER	1
14	12-0814-01-07	BELT 210X137/ 16-83A	1
15	01-2034-01-3	SPECIAL SCREW FOR HANDLE	2

UPRIGHT VACUUM CLEANER INTERNAL PARTS

PARTES INTERNAS BARREDORA U-75

REV. 24-JUN-2009

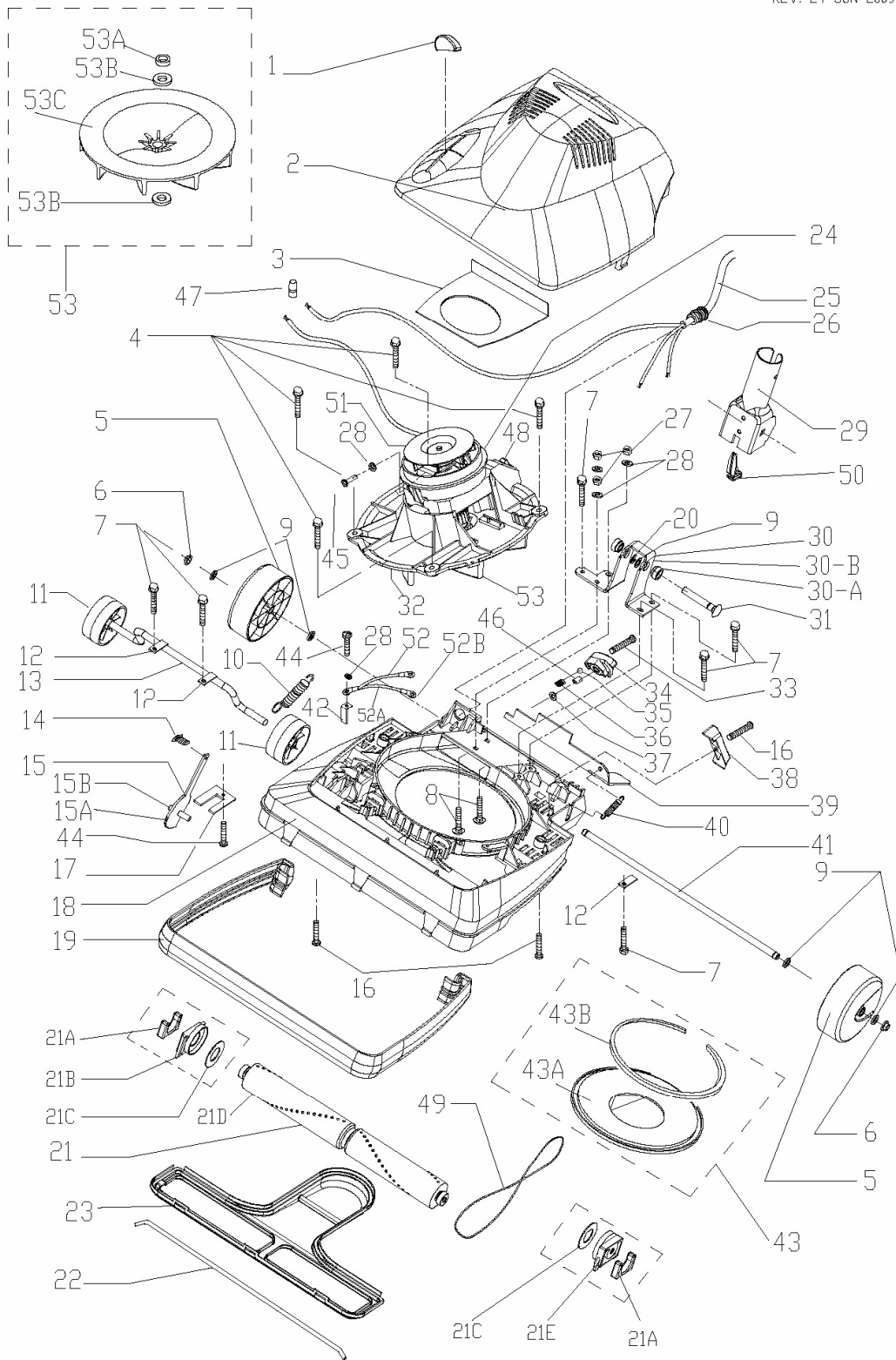

IX. – UPRIGHT VACUUM CLEANER INTERNAL PARTS LIST

No	PART No.	DESCRIPTION	U-75
1	13-3147-9	KNOB CAM	1
2	13-2949-9	PLASTIC COVER U-75	1
3	12-0936-0	BAFFLE	1
4	01-15006	SCREW B TYPE 10-16x3/4	4
5	13-3144-6	BACK WHEEL U-75	2
6	04-0671-0	WASHER CAP RETAINER	2
7	01-1499-1	SCREW HEXAGONAL No 10-16x5/8	6
8	01-0664-1	SCREW 10x 5/8	2
9	04-0589-4	FLAT WASHER 5/16 X 1/2	3
10	24-0308-7	FRONT AXLE SPRING	1
11	13-3143-8	FRONT WHEEL U-75	2
12	05-4489-0	AXLE RETAINER PLATE	3
13	25-1349-02-3	GALVANIZED FRONT AXLE	1
14	01-1651-7	SCREW B TYPE No 6	1
15	46-3206-3	CAM ASSY	1
15-A	05-4722-4	U-75 CAM	1
15-B	25-1345-5	BOLT FOR CAM	1
16	01-0093-3	SCREW No 6x5/8 TYPE BC/PHILLIPS	2
17	05-4721-6	CAM RETAINER PLATE	1
18	13-2883-0	POLYCARBONATE CHASSIS	1
19	12-0952-7	U-75 BUMPER GUARD	1
20	04-0469-9	PO-25 LOCK WASHER	1
21	46-2375-7	BRUSH ROLL ASSY W/END CAPS	1
21-A	12-0522-8	GASKET END CAP	1
21-B	13-1801-3	LEFT BEARING SUPPORT	1
21-C	37-0130-7	FELT WASHER	2
21-D	45-0299-3	USE 46-2375-7	1
21-E	13-1252-9	11/16 BEARING	1
22	25-0997-4	BOTTOM PLATE RETAINER	1
23	46-3207-1	BOTTOM PLATE	1
24	13-3146-1	MOTOR COOLING COVER	1
25	28-1644-5	CABLE OF U-75 LINE ASSEMBLY	1
26	12-0953-5	GROMMET HEYCO 1232	1
27	02-0041-0	HEXAGONAL NUT No.10-24	3
28	04-0271-9	WASHER STARS No 10X.204	5
29	05-4734-02-5	CHROMED YOKE	1
30	46-3260-0	YOKE SUPPORT BUSHING ASSY	1
30-A	13-3148-7	BUSHING YOKE	2
30-B	05-4725-7	YOKE SUPPORT	1
31	25-1346-3	BOLT FOR YOKE	1
32	12-0495-01-5	MOTOR MOUNT GASKET	1
33	01-0285-5	SCREW 8x 3/4	2
34	13-2126-4	BAG KNOB	1
35	26-0001-3	BALL ARM SHAFT/R -30465P2	1
36	24-0014-1	KNOB SPRNG	1

No	PART No	DESCRIPTION	U-75
37	04-0026-7	FLAT WASHER (02-0101)	1
38	13-2127-2	BAG SUPPORT	1
39	05-4724-02-6	HANDLE PEDAL	1
40	24-0316-0	PEDAL SPRING	1
41	25-1322-4	REAR AXLE	1
42	05-4993-1	GROUNDING TERMINAL	1
43	46-3208-9	FAN COVER ASSEMBLY	2
43-A	13-3145-3	FAN COVER	1
43-B	12-0834-7	FAN COVER GASKET	1
44	01-0270-7	SCREW PHILLIPS 6 x 3/8 " " A "	2
45	01-1683-0	SCREW T TYPE 8-32 x 1/4	1
46	05-0997-6	SPACER	1
47	10-0137-9	CABLE CONNECTOR	1
48	11-0159-1	BALANCE SWITCH	1
49	12-0814-01-7	BELT .210x13 7/16 83A	1
50	13-3273-3	SWITCH ACTUATOR	1
51	46-3099-2	ASSY U-75 MOTOR	1
52	28-1664-3	GROUND CORD ASSY	1
52-A	09-1319-4	GROUNDING CABLE	2
52-B	30-0197-1	TERMINAL OF EARTH RETURN	3
53	45-0524-4	LEXAN FAN KIT	1
53A	04-0123-2	BUJE P/TURBINA PLASTICO	1
53B	13-2442-5	RONDANA DE FIBRA 0 INT. .315	2
53C	26-0221-7	TURBINA 9 ALETAS	1



FACTORY AUTHORIZED SERVICE Thorne
Electric Company
610 Lanark Suite 205 San Antonio TX, 78218
Tel (210) 590-1226
Fax (210) 590-1258
1-800-548-5741

FACTORY Koblenz Eléctrica, S.A. de C. V.
Av. Ciencia No 28 Cuautitlan Izcalli
Edo. de México,
C. P. 54730 Tel: 52 (55) 5864-0300
Web site: <http://www.koblenz.electric.com>

KOBLENZ ELECTRICA S.A. DE C. V.
E-mail: thorne_scsm@koblenz-electric.com

LP-200906

S
E
R
V
I
C
E