

# SHURflo<sup>®</sup>

## Industrial Series 2088 Pumps

### Installation and Operations Manual

SHURflo offers various pumps models for different applications. The information outlined by this manual is general, and not specific to all 2088 series pumps. Be certain the pumps' materials will be compatible with the fluid being pumped. 2088 series pumps are intended for intermittent or continuous duty when the proper operating criteria are met. Product Data Sheets outlining specific thermal limits, load, flow curves, and other technical information for a particular model are available. If unsure of the chemical compatibility with a given elastomer or the motors intended design, please call SHURflo for assistance.

**CAUTION:** "Intermittent Duty" is defined as; operated and/or frequently started within a period of time that would cause the motor to reach its maximum thermal limits. Once the maximum thermal limit is obtained, the motor must be allowed to return to ambient temperature before resuming operation.

**CAUTION:** **DO NOT** use to pump flammable liquids. Never operate the pump in an explosive environment. Arcing from the motor brushes, switch or excessive heat from an improperly cycled motor may cause an explosion.

**CAUTION:** **DO NOT** assume fluid compatibility. If the fluid is improperly matched to the pumps' elastomers, a leak may occur. Pumps used to transfer hazardous or hot (max. temperature 170°F [76°C] viton only) chemicals must be in a vented area to guard against the possibility of injury due to harmful or explosive liquid/vapors.

**CAUTION:** **DO NOT** operate the pump at pressures which cause the motor to exceed the amperes rating indicated on the name plate. Various pump models are equipped with thermal breakers to interrupt operation due to excessive heat. Once the temperature of the motor is within proper limits it will automatically reset, and the pump **will start operation without warning**.

**CAUTION:** To prevent electrical shock, disconnect power before initiating any work. In the case of pump failure, the motor housing and/or the pumped fluid may carry high voltage to components normally considered safe.

#### **PRESSURE SWITCH OPERATION**

The pressure switch reacts to outlet pressure, and interrupts power at the preset shut-off pressure indicated on the pump label. When outlet pressure drops below a predetermined limit (typically 15-20 psi.[1-1.4 bar] less than the shut-off pressure), the switch will close and the pump will operate until the shut-off (high) pressure is achieved. The shut-off pressure is set to factory calibrated standards. See the motor label and Product Data Sheet for specific pump specifications.

**CAUTION:** Improper adjustment of the pressure switch may cause severe overload or premature failure. Refer to SHURflo Service Bulletin #1031 for the adjustment procedure. Failures due to improper adjustment of the pressure switch will not be covered under the limited warranty.

If the plumbing is restrictive or the flow rate is very low, the pump may re-pressurize the outlet faster than the fluid is being released causing rapid cycling (ON/OFF WITHIN 2 seconds). If the pump is subjected to rapid cycling during normal operation, or for infrequent periods, damage may occur. Applications which exhibit rapid cycling should have restrictions in the outlet minimized. If not feasible, consider a SHURflo Accumulator or a SHURflo "bypass" model pump.

#### **BYPASS OPERATION**

A bypass pump may be used for applications that normally induce frequent start/stop of the motor, and thereby create a potential for overheating. Models equipped with an internal bypass are designed to pump at high pressure while at low flow rates. Bypass models equipped with a switch may operate for several seconds even though the outlet side has been closed off. Contact SHURflo for information regarding bypass pumps.

## **MOUNTING**

- The 2088 series pumps are self priming. Horizontal and vertical prime vary depending on the fluid viscosity and pump configuration. Refer to the pumps Product Data Sheet.
- The pump should be located in an area that is dry and provides adequate ventilation. If mounted within an enclosure, provisions to cool the motor may be necessary. Heat sinks which attach to the motor are available from SHURflo if increased heat dissipation is necessary.

**CAUTION:** *DO NOT* locate the motor near low temperature plastics or combustible materials. The surface temperature of the motor may exceed 250°F [120°C]. Refer to the pumps Product Data Sheet.

- The pump may be mounted in any position. However, if mounting the pump vertically the pump head should be in the down position so that in the event of a leak, fluid will not enter the motor.
- Secure the rubber feet with #8 hardware. *DO NOT* compress the feet, doing so will reduce their ability to isolate vibration/noise.

## **PLUMBING**

- Flexible high pressure tubing compatible with the fluid should be used to connect the inlet/outlet ports. Tubing should be either 3/8" or 1/2" [10 or 13 mm] I.D., and at least 18 in. [46 cm] length is suggested to minimize stress on the fitting/ports and reduce noise. Allow for the shortest possible tubing route and avoid sharp bends that may kink over time.

**NOTE:** Restrictions on the inlet may cause vacuum levels to reach the fluid vapor pressure, causing cavitations, degassing, vapor lock and a loss in performance. Inlet pressure *must* not exceed 30 psi.[2.1 bar] maximum.

- **1/2" Male threaded models:** Are intended to be used with SHURflo Swivel Barb Fittings which seal with an internal taper when *hand tightened*. Standard 1/2" NPT fittings may be used when tightened to a maximum torque of 3.7 ft\lb (45 in\lb) [5 Nm].

**NOTE:** SHURflo does not recommend the use of metal fittings or rigid pipe to plumb the inlet/outlet ports. Standard plastic male and female threaded fittings can be acquired at commercial plumbing supply stores. SHURflo also distributes Swivel Barb Fittings, and special fitting through its dealers (Form #07-010-0011).

**CAUTION:** Sealers and Teflon tape may act as lubricant causing cracked housings or stripped threads due to over-tightening. Care should be used when applying sealers. Sealers may enter the pump inhibiting valve action, causing no prime or no shut-off. *A failure due to foreign debris is not covered under warranty.*

- Installation of a 50 mesh strainer is recommended to prevent foreign debris from entering the pump.
- If a check valve is installed in the plumbing, it must have a cracking pressure of no more than 2 psi [.14 bar].

## **ELECTRICAL**

**CAUTION:** Electrical wiring should be performed by a qualified electrician, in accordance with all local electrical codes.

- The pump should be on a dedicated (individual) circuit, controlled with a double pole switch (U.L./C-UL certified) rated at or above the fuse ampere indicated by the pump motor label. Depending on distance of the power source from the pump and ampere load on the circuit, wire may need to be heavier than indicated by the chart.

**CAUTION:** All 115 VAC and 230 VAC pump motors and systems, *MUST* be ground per local and state electrical codes.

- Improper duty cycle and/or rapid start & stop conditions may cause the internal thermal breaker (if equipped) to trip, or can result in premature motor failure due to excessive heat. Refer to the pumps Product Data Sheet.

- For the pump to meet U.L./C-UL requirements the circuit ***MUST be protected with a slow-blow fuse*** (U.L./C-UL certified) or equivalent circuit breaker as indicated on the motor label. Use an approved wire of the size specified or heavier.

VOLTAGE	WIRE LEADS	WIRE SIZE	FUSE RATING
12 DC	RED (positive +) BLACK (negative -)	#14 AWG [2.5 Mm <sup>2</sup> ] (or heavier)	SEE PUMP MOTOR LABEL
24 DC			
36 DC			
115 AC	BLACK (common) WHITE(neutral) GREEN (ground)	#16 AWG C-UL - TEW / UL 1015	
230 ACⓄ	BROWN (common) BLUE (neutral) GRN/YELL (ground)	(or heavier) [1 Mm <sup>2</sup> ]	

**CAUTION:** Circuit protection is dependent on the individual application requirements. Failure to provide proper overload / thermal devices may result in a motor failure, which will not be covered under warranty.

### TROUBLESHOOTING

#### PUMP WILL NOT START:

- ✓ Fuse or breaker
- ✓ For correct voltage (±10%) and electrical connections
- ✓ Pressure switch operation and correct voltage at switch or motor wires (as equipped).
- ✓ Rectifier or motor for open or grounded circuit
- ✓ For locked drive assembly

#### WILL NOT PRIME: (No discharge/Motor runs)

- ✓ Out of product
- ✓ Strainer for debris
- ✓ Inlet tubing/plumbing for severe vacuum leak
- ✓ Inlet/Outlet tubing severely restricted (kinked)
- ✓ Debris in pump inlet/outlet valves
- ✓ Proper voltage with the pump operating (±10%)
- ✓ Pump housing for cracks

#### LEAKS FROM PUMP HEAD OR SWITCH:

- ✓ For loose screws at switch or pump head.
- ✓ Switch diaphragm ruptured or pinched

- ✓ For punctured diaphragm if fluid is present at bottom drain

#### PUMP WILL NOT SHUT-OFF: (Pressure switch equipped)

- ✓ Output line closed and no leaks
- ✓ For air trapped in outlet line or pump head
- ✓ For correct voltage to pump (±10%)
- ✓ Inlet/Outlet valves for debris or swelling
- ✓ For loose drive assembly or pump head screws
- ✓ Pressure switch operation/adjustment incorrect refer to S/B #1031 for differential and pressure adjustment procedure

#### NOISY / ROUGH OPERATION:

- ✓ Mounting feet that are compressed to tight
- ✓ Does the mounting surface multiply noise (flexible)
- ✓ For loose pump head or drive screws
- ✓ Is the pump plumbed with rigid pipe causing noise to transmit?

### SERVICE KITS

Kits are readily available to repair standard 2088 series pumps. Repair kits include simple illustrated instructions allowing easy installation. To insure that the correct kit is received the model numbered and all name plate data must be included with the order. Contact a SHURflo distributor or SHURflo directly to order the necessary repair kit.

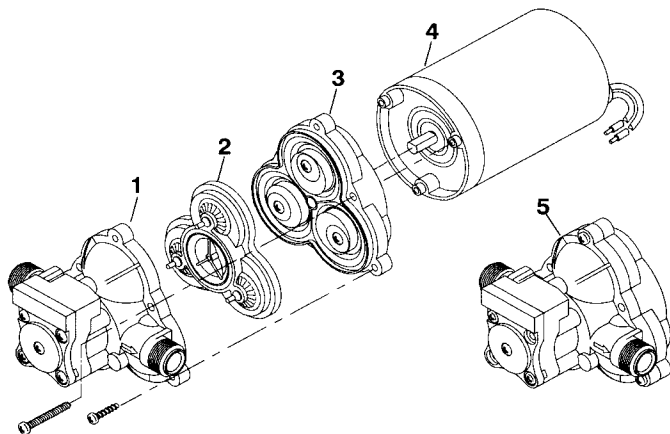

1	Switch / Check valve and Upper Housing Kit
2	Valve plate assembly
3	Diaphragm / Drive assembly
4	Motor
5	Complete Pump Head assembly (includes parts # 1,2,3)

## **RETURN POLICY**

All Industrial pumps/products **must** be flushed of **any** chemical (ref. OSHA Section 1910.1200 (d)(e)(f)(g)(h)) and hazardous chemicals **must** be labeled/tagged before being \*shipped to SHURflo for service or warranty consideration. SHURflo reserves the right to request a Material Safety Data Sheet from the returnee for any pump/product it deems necessary. SHURflo reserves the right to "disposition as scrap" pumps/products returned which contain unknown fluids. SHURflo reserves the right to charge the returnee for any and all costs incurred for chemical testing, and proper disposal of components containing unknown fluids. SHURflo request this in order to protect the environment and personnel from the hazards of handling unknown fluids.

## **LIMITED WARRANTY PROCEDURE**

SHURflo warrants Industrial 2088 series pumps to be free from material and workmanship defects (under normal use and service) for a period of one (1) year from the date of manufacture, or (1) one year use with proof of purchase, not to exceed (2) two years in any event.

The limited warranty will not apply to pumps that were improperly installed, misapplied, or incompatible with fluids or components not manufactured by SHURflo. SHURflo will not warrant any pump which is damaged or modified outside the SHURflo factory.

All Industrial pumps/products **must** be flush of **any** chemicals before \*shipping. All warranty considerations are governed by SHURflo's written Return Policy.

Returns are to be shipped postage prepaid to either service center; SHURflo Cypress, CA or Elkhart, IN. SHURflo shall not be liable for freight damage incurred during shipping. Package returns carefully.

Upon receiving a pump, it will be tested per SHURflo's test criteria. SHURflo's obligation under this warranty policy is limited to the repair or replacement of the unit. Pumps found not defective (under the terms of this limited warranty) are subject to charges to be paid by the returnee for the testing and packaging of "tested good" units.

No credit or labor allowances will be given to the returnee for pumps returned as defective. Warranty replacements will be shipped on a freight allowed basis. SHURflo reserves the right to choose the method of transportation.

This limited warranty is in lieu of all other warranties, expressed or implied, and no other person is authorized to give any other warranty or assume obligation or liability on SHURflo's behalf. SHURflo shall not be liable for any labor, damage or other expense, nor shall SHURflo be liable for any indirect, incidental or consequential damages of any kind incurred by the reason of the use or sale of any defective product or part. This limited warranty covers pumps distributed within the United States of America. Other world market areas should consult with the distributor for any deviation from this document.

Carriers, including U.S.P.S., airlines, UPS, ground freight, etc., require specific identification of any hazardous materials being shipped. Check with your shipping company for specific instructions. Failure to do so may result in substantial penalties.



### **SHURFLO**

3545 Harbor Gateway South, Ste. 103, Costa Mesa, CA 92626, (800) 854-3218 [www.shurflo.com](http://www.shurflo.com)

**SHURFLO Europe, Middle East, Africa**

Pentair Water Belgium bvba, Industriepark Woflste, Toekomstlaan 30, B-2200 Herentals, Belgium, +32-14-283500

All Pentair trademarks and logos are owned by Pentair, Inc. All other brand or product names are trademarks or registered marks of their respective owners.

Because we are continuously improving our products and services, Pentair reserves the right to change specifications without prior notice.

Pentair is an equal opportunity employer.

911-396 Rev P 06/12 ©Pentair, Inc. All Rights Reserved